

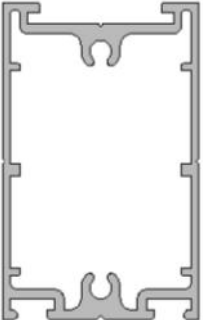

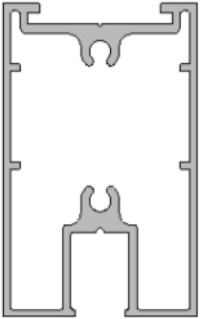

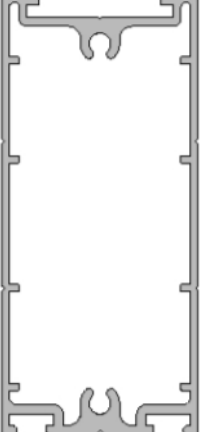

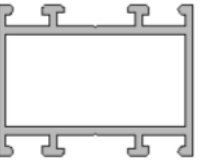

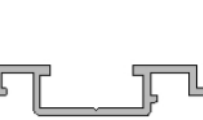

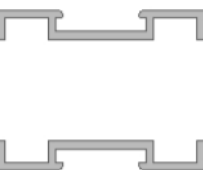

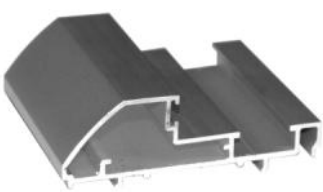







# Technique et pose





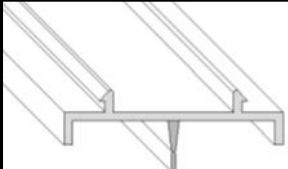



Porte  
Cadre  
Alu.

	<p><b>PP65</b></p>	<p>Profil de porte Golf Ht. 65 mm à parecloses Profil aluminium finition anodisée ou laquée Longueur : 5580 mm</p>
	<p><b>PP65V</b></p>	<p>Profil de porte vitrée Opalys et Lounge Ht. 65 mm à feuillure Profil aluminium finition anodisée ou laquée Longueur : 5580 mm</p>
	<p><b>PP90</b></p>	<p>Profil de porte Cozy, Glide et Club Ht. 90 mm à parecloses Profil aluminium finition anodisée ou laquée Longueur : 6030 mm</p>
	<p><b>TP 40</b></p>	<p>Profil de traverse intermédiaire Ht. 31 mm Profil aluminium finition anodisée ou laquée Longueur : 6030 mm</p>
	<p><b>FP 40</b></p>	<p>Profil de frappe pour porte double Profil aluminium finition anodisée ou laquée Longueur : 4200 mm</p>
	<p><b>AV65 2</b></p>	<p>Profil pour double vitrages sur porte Profil aluminium finition anodisée ou laquée Longueur : 6030 mm</p>
	<p><b>T 65</b></p>	<p>Profil de traverse intermédiaire pour porte avec double vitrages sur AV65 2 Profil aluminium finition anodisée ou laquée Longueur : 6030 et 5250 mm</p>







	<b>BR 65</b>	Profil de battée universelle Série 65 et Ecozal Profil aluminium finition anodisée ou laquée Longueur : 6030 et 5250 mm
	<b>MBR</b>	Profil de battée universelle Mistral 85 Profil aluminium finition anodisée ou laquée Longueur : 6030 et 5250 mm
	<b>BR70</b>	Profil de battée universelle Eazy 72 Profil aluminium finition laquée Longueur : 5250 mm
	<b>JB17</b>	Jonc de finition pour frappe FP40 et battées BR65, MBR et SBU Profil PVC coloris gris clair ou noir Longueur : 5250 mm
	<b>PUA</b>	Paumelle réversible pour porte alu Montage côté bâti avec contre plaque à insérer avant montage de la battée Finition anodisée ou laquée Ral 9010
	<b>Gâche Inox</b>	Gâche inox pour frappe et battée Finition inox
	<b>PV5 B</b>	Joint pour battée (BR65, BR70, MBR, SBU, VBU) Pour porte bois, aluminium et verre Profil EPDM coloris noir En longueur de 5350 mm
	<b>JVP</b>	Joint de vitrage pour porte PP65V Pour vitrage feuilleté 33.2 ( 6.8mm ) Profil PVC coloris gris foncé à lèvres cristal Longueur : 6000 mm
	<b>JFP</b>	Joint de frappe FP40 pour porte double Profil PVC noir Longueur : 6000 mm

	<b>EPA P</b>	Équerre d'assemblage pour PP65, PP65V et PP90 en coupe 45°
	<b>A 43</b>	Agrafe et came d'assemblage pour TP 40
	<b>A 93</b>	Agrafe et came d'assemblage Pour traverse intermédiaire T 65 sur AV65 / 2
	<b>C 6</b>	Clef 6 pans de montage pour A 43 et A 93
	<b>R 93</b>	Ressort d'écartement double panneaux sur T65 et AV65 / 2 1 pièce tous les 500 mm
	<b>VFPAR</b>	Verrou haut et bas pour frappe FP 40 de battant semi fixe 2 pièces par battant semi fixe
	<b>JCP</b>	Jonc de finition pour champ de porte Profil PVC noir Longueur : 6150 mm
	<b>JDP</b>	Joint d'étanchéité de dessous de porte Profil PVC noir Longueur : 6000 mm
	<b>U de 40 x 25</b>	U de guidage bas de porte coulissante Profil aluminium finition anodisée ou laquée Longueur : 6000 mm

# Parecloses PVC

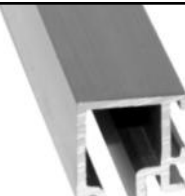
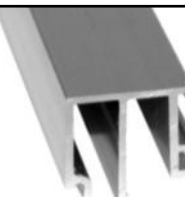
	<b>PV 3</b>	Pareclose PVC couleur de 3 mm Longueur : 6030 mm
	<b>PV 10</b>	Pareclose PVC couleur de 10 mm Longueur : 6030 mm
	<b>PV 15</b>	Pareclose PVC couleur de 15 mm Longueur : 6030 mm
	<b>PV 19</b>	Pareclose PVC couleur de 19 mm Longueur : 6030 mm
	<b>PV 23</b>	Pareclose PVC couleur de 23 mm Longueur : 6030 mm
	<b>PV 27</b>	Pareclose PVC couleur de 27 mm Longueur : 6030 mm
	<b>PVDV 65</b>	Ecarteur pour double vitrages Profil PVC coloris gris clair ou noir Longueur : 6030 mm
	<b>PVDV 65 SL</b>	Ecarteur pour double vitrages 8 et 10 mm Profil PVC coloris gris clair ou noir Longueur : 6030 mm

## Parecloses alu.

	<b>PA 3</b>	Pareclose alu. de 3 mm Finition anodisée ou laquée Longueur : 6030 mm
	<b>PA 10</b>	Pareclose alu. de 10 mm Finition anodisée ou laquée Longueur : 6030 mm
	<b>PA 15</b>	Pareclose alu. de 15 mm Finition anodisée ou laquée Longueur : 6030 mm
	<b>PA 19</b>	Pareclose alu. de 19 mm Finition anodisée ou laquée Longueur : 6030 mm
	<b>PA 23</b>	Pareclose alu. de 23 mm Finition anodisée ou laquée Longueur : 6030 mm
	<b>PA 27</b>	Pareclose alu. de 27 mm Finition anodisée ou laquée Longueur : 6030 mm
	<b>PV 8</b>	Joint pour pareclose alu. Coloris noir ou cristal Longueur : 6030 mm

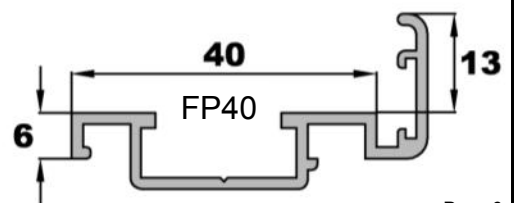
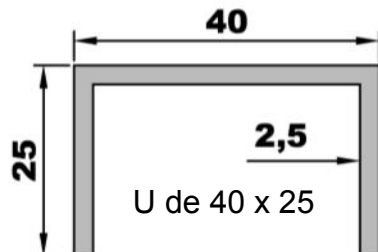
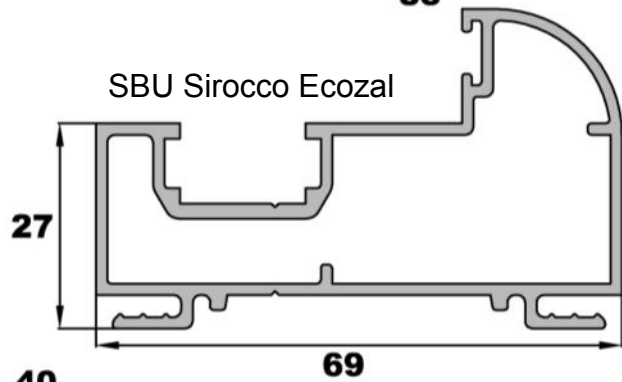
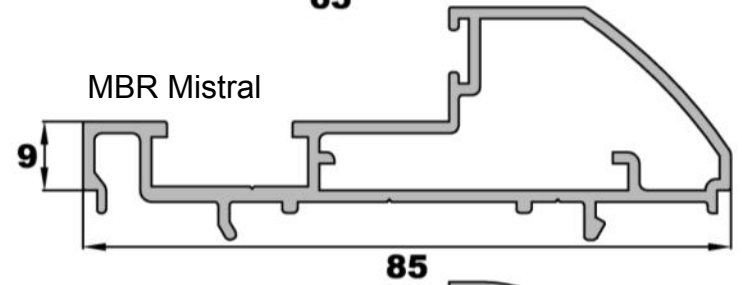
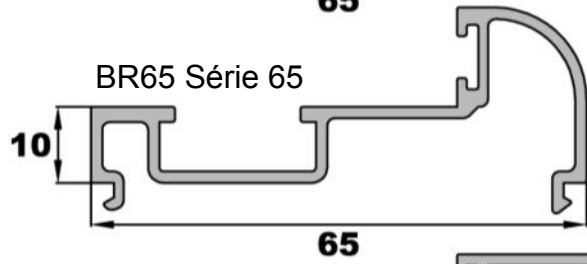
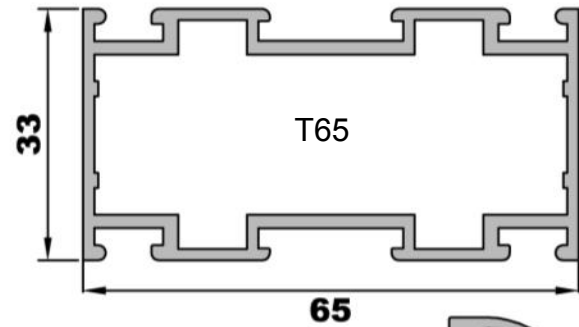
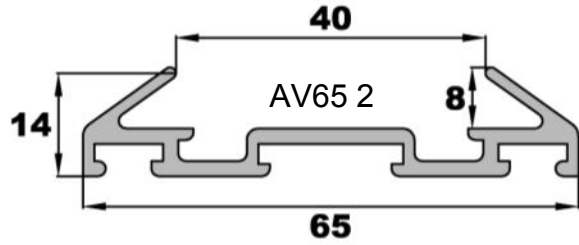
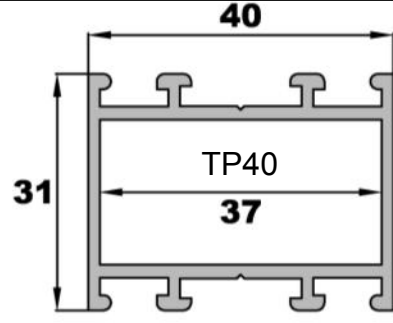
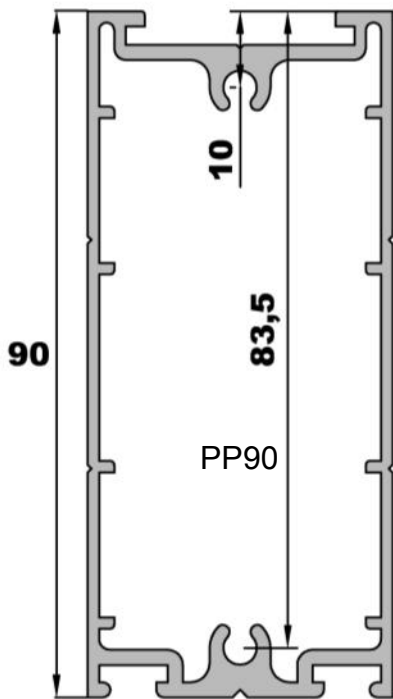
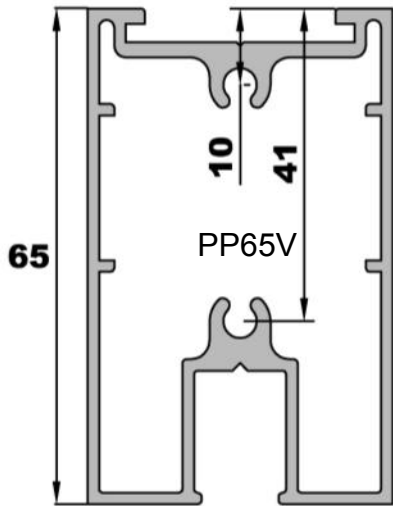
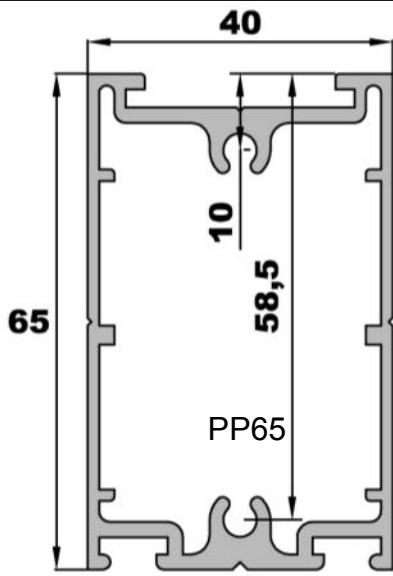





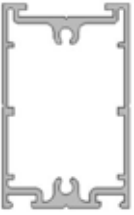
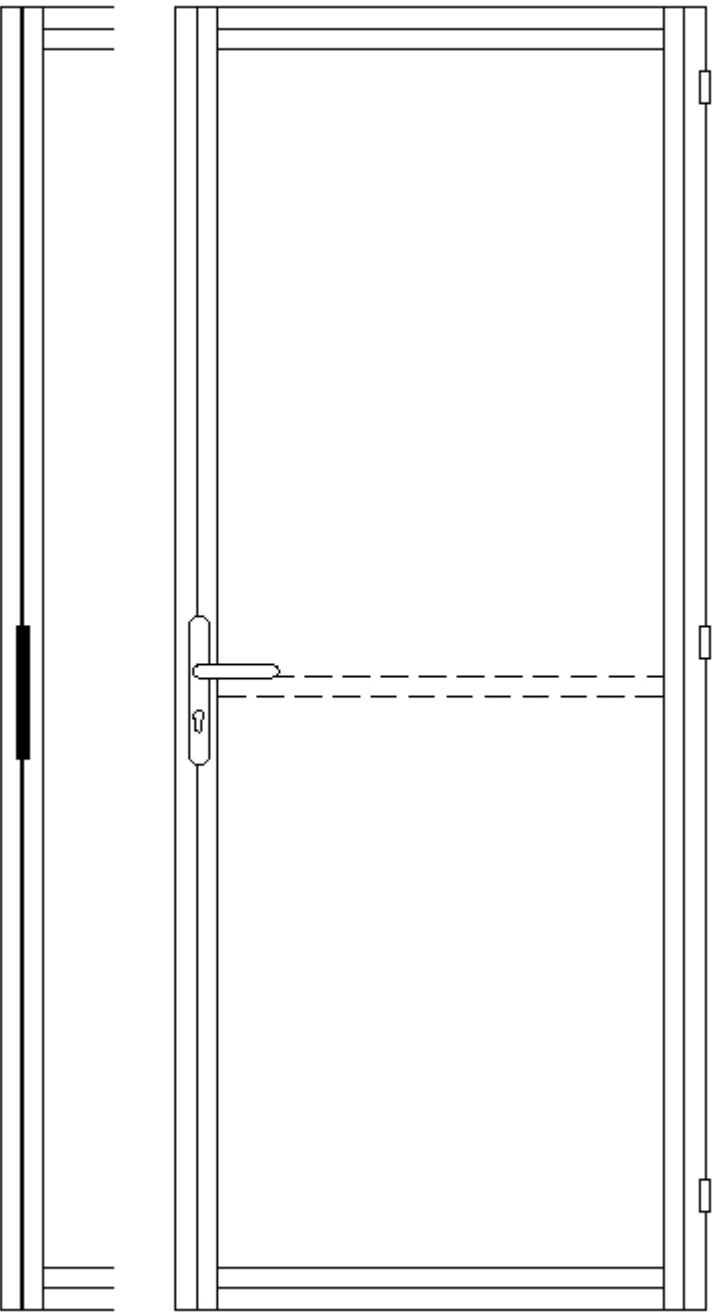
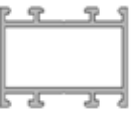

## Portes PP65 et PP90

### Choix des parecloses aluminium ou PVC selon les épaisseurs de remplissage

Épaisseur de remplissage	Parecloses PVC	Parecloses alu. + joint PV8
5 à 6.8 mm	PV19 + PV10	PA19 + PA10
10 à 10.8 mm	PV15 + PV10	PA15 + PA10
12 à 14 mm	PV3 + PV19	PA3 + PA19
16 mm	PV3 + PV15	PA3 + PA15
2 panneaux de 12 ou 13 mm	2 PV3 + mousse de calage	2 PA3 + mousse de calage

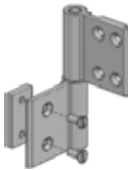
# Porte Golf PP65 coupe 90° Béquille double sur plaque

	PP65	
	TP40	
	Serrure SEROZ largeur 46 entraxe 70 carré de 8	
	Cylindre Eu 35x35	
	Béquille double sur plaque entraxe 70 carré de 7	
	KIT1 PUA	
	PV5 B	
	Fourreau réducteur	

## Débit des montants et traverses (mm) :

Battant de service de 2040 X 830 :

PP65 : 2 fois 2040 (2C90°), 2 fois 700 (2C90°)

TP40 : 1 fois 700 (en cas de traverse intermédiaire )

Dimension de remplissage (sans traverse) : 1902 X 692 mm

# Porte Golf PP65 coupe 90° Béquille double sur plaque

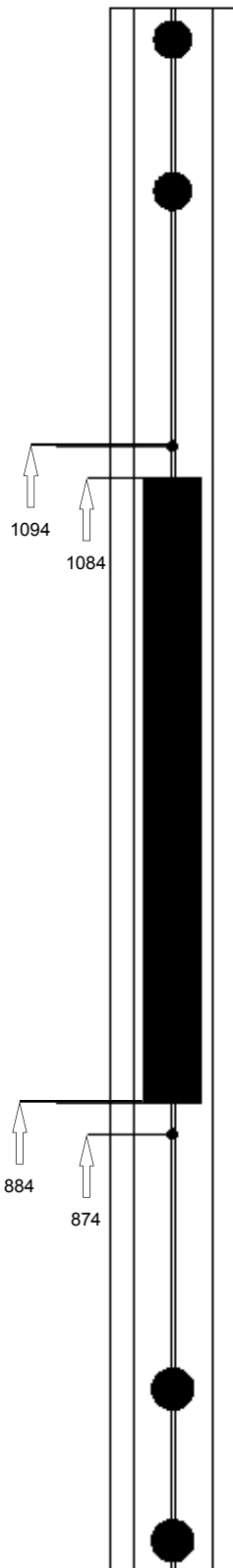
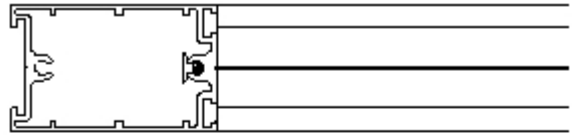



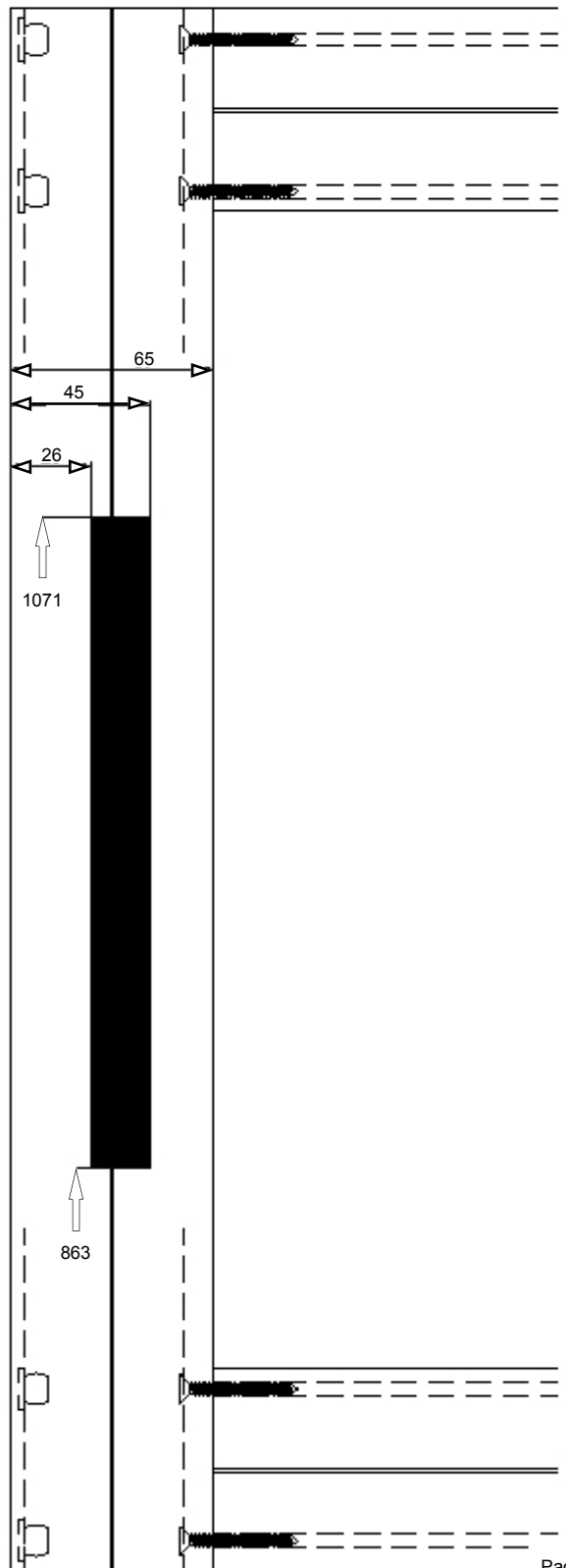



Usinage pour  
Serrure  
1 point  
SEROZ  
Coffre de 46  
Entraxe 70  
Carré de 8 mm

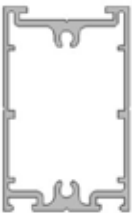
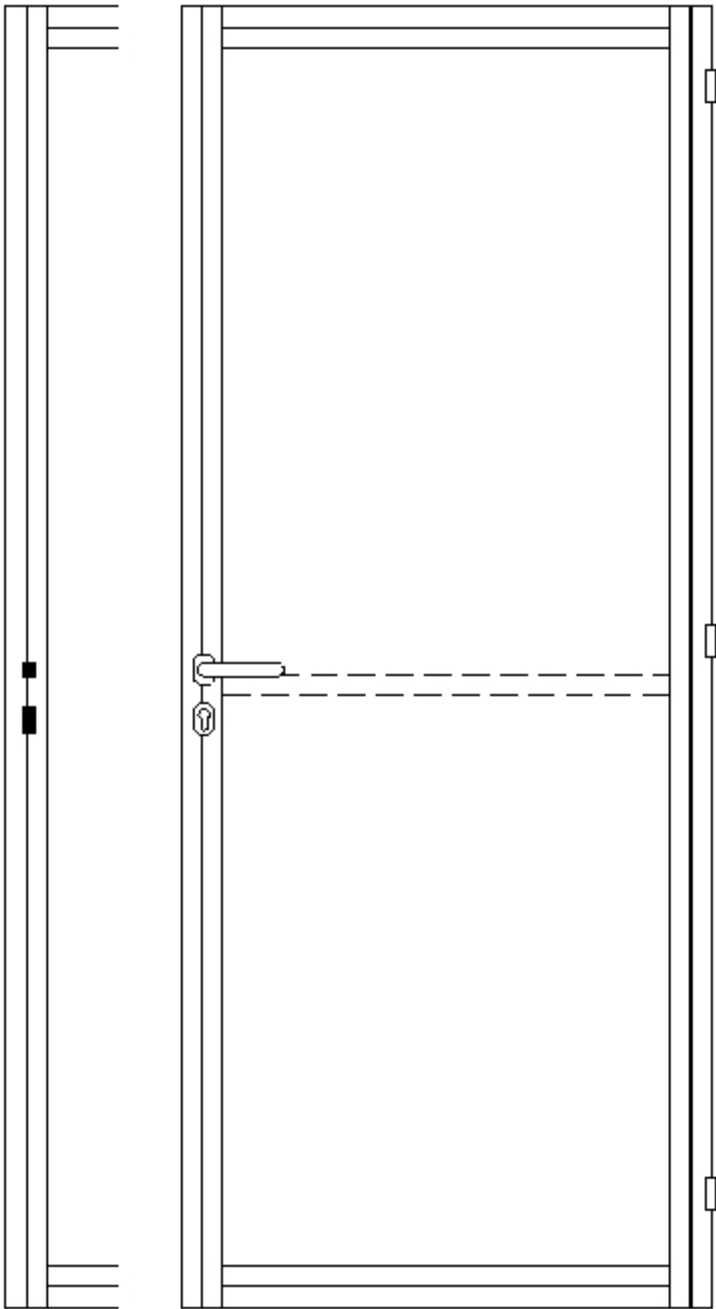
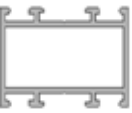

# Porte Golf PP65 coupe 90°

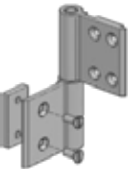
## Béquille double et entrée de cylindre

	PP65	
	TP40	
	Serrure SEROZ largeur 46 entraxe 70 carré de 8	
	Cylindre Eu 35x35	
	Béquille double carré de 7	
	Entrée de cylindre	
	KIT1 PUA	
	PV5 B	
	Fourreau réducteur	

### Débit des montants et traverses (mm) :

Battant de service de 2040 X 830 :

PP65 : 2 fois 2040 (2C90°), 2 fois 700 (2C90°)

TP40 : 1 fois 700 (en cas de traverse intermédiaire )

Dimension de remplissage (sans traverse) : 1902 X 692 mm

# Porte Golf PP65 coupe 90°



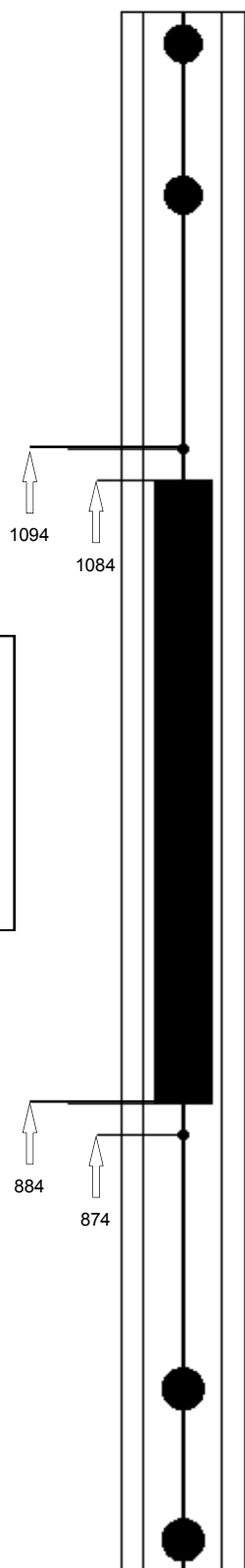
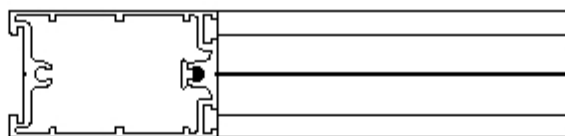

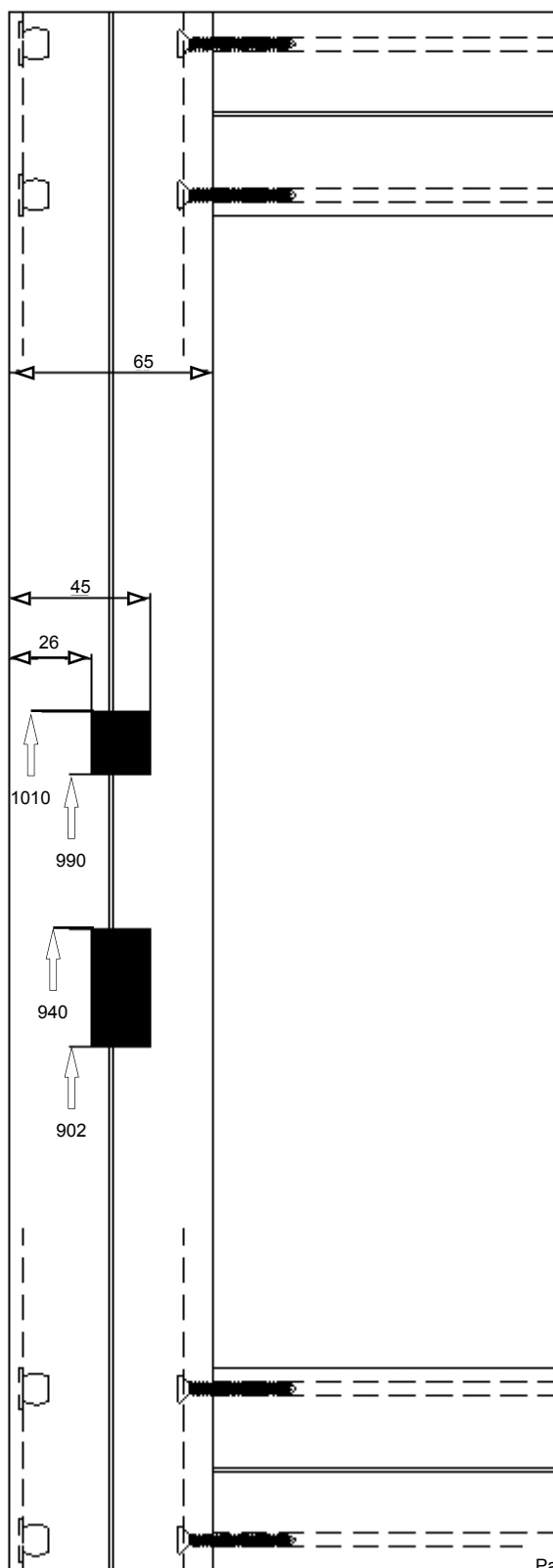

## Béquille double et entrée de cylindre

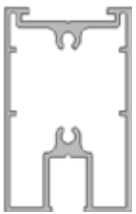
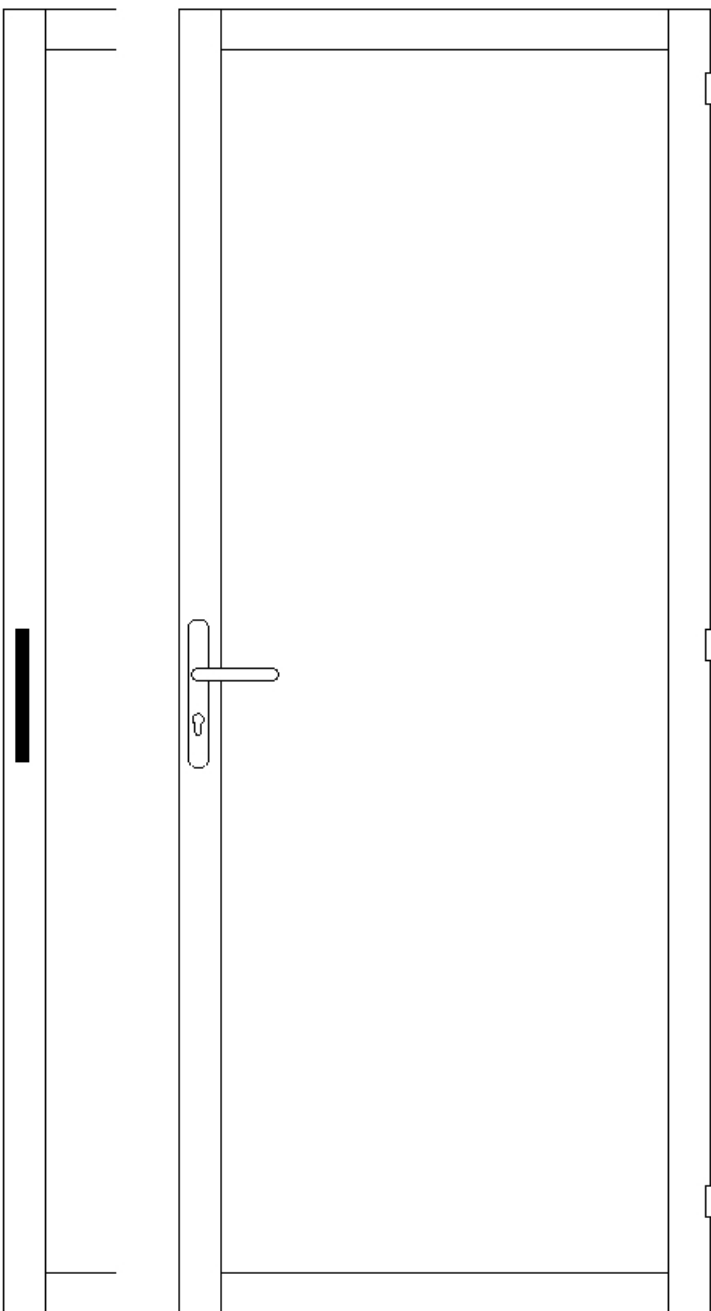

Usinage pour  
Serrure  
1 point  
SEROZ  
Coffre de 46  
Entraxe 70  
Carré de 8 mm

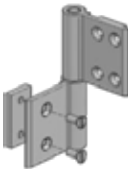

# Porte Opalys vitrée 33.2 coupe 90° Béquille double sur plaque

	PP65V	
	JVP	
	Serrure SERPP65V largeur 41 entraxe 92 carré de 8	
	Cylindre Eu 35x35	
	Béquille double sur plaque entraxe 92 carré de 8	
	KIT1 PUA	
	PV5 B	

## Débit des montants et traverses (mm) :

Battant de service de 2040 X 830 :

PP65V : 2 fois 2040 (2C90°), 2 fois 700 (2C90°)

JPV : 2 fois 1945, 2 fois 700





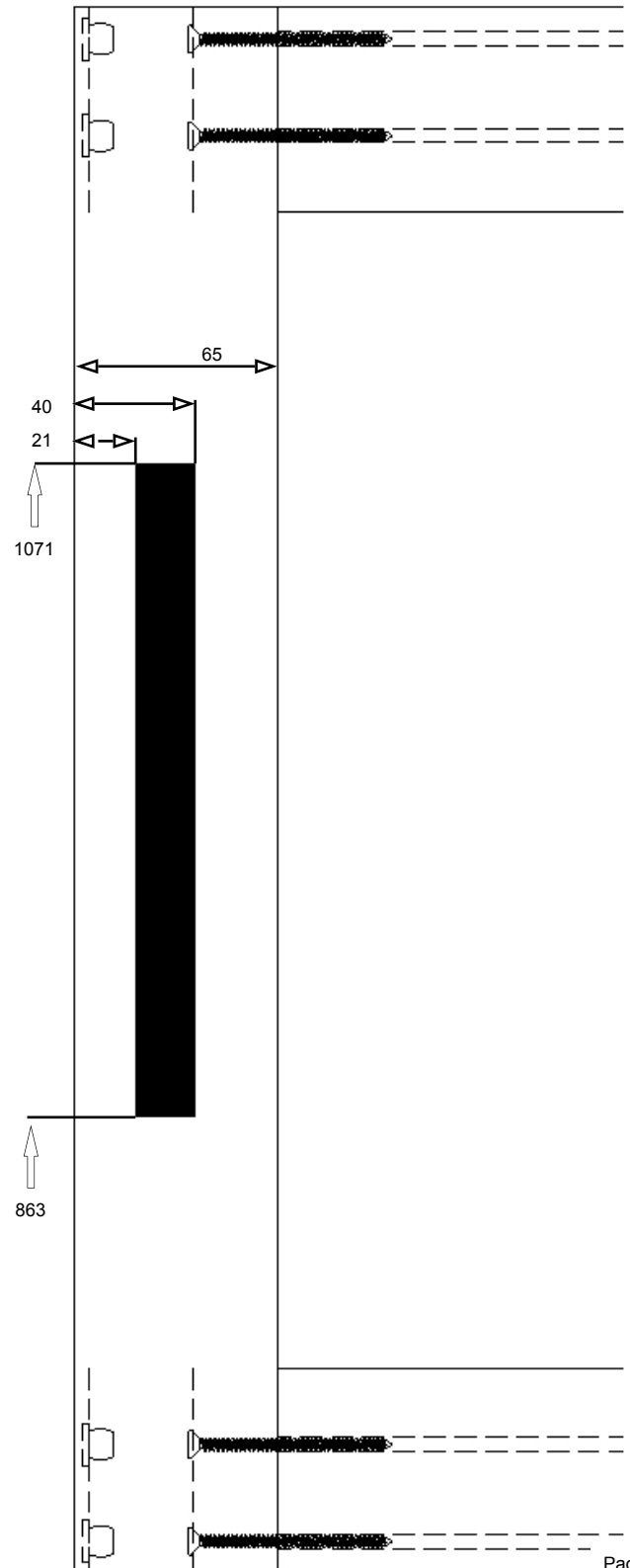
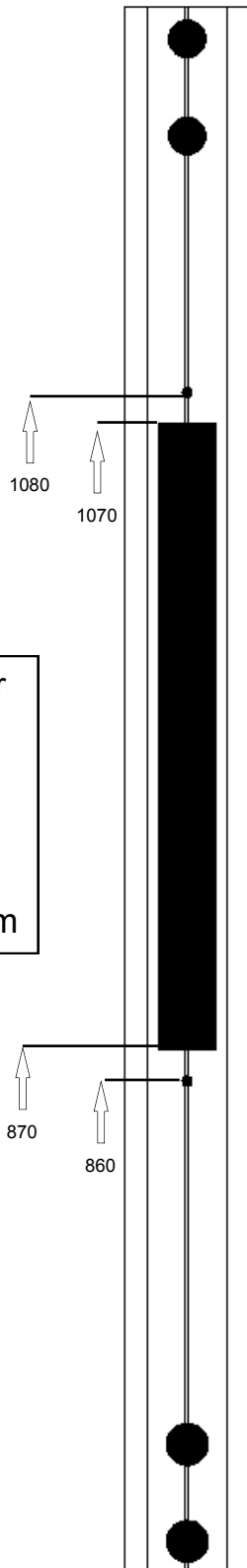
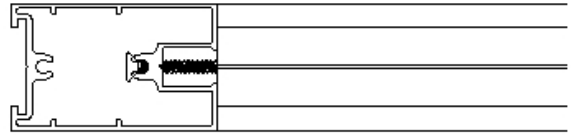

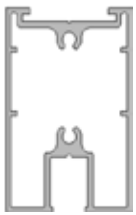
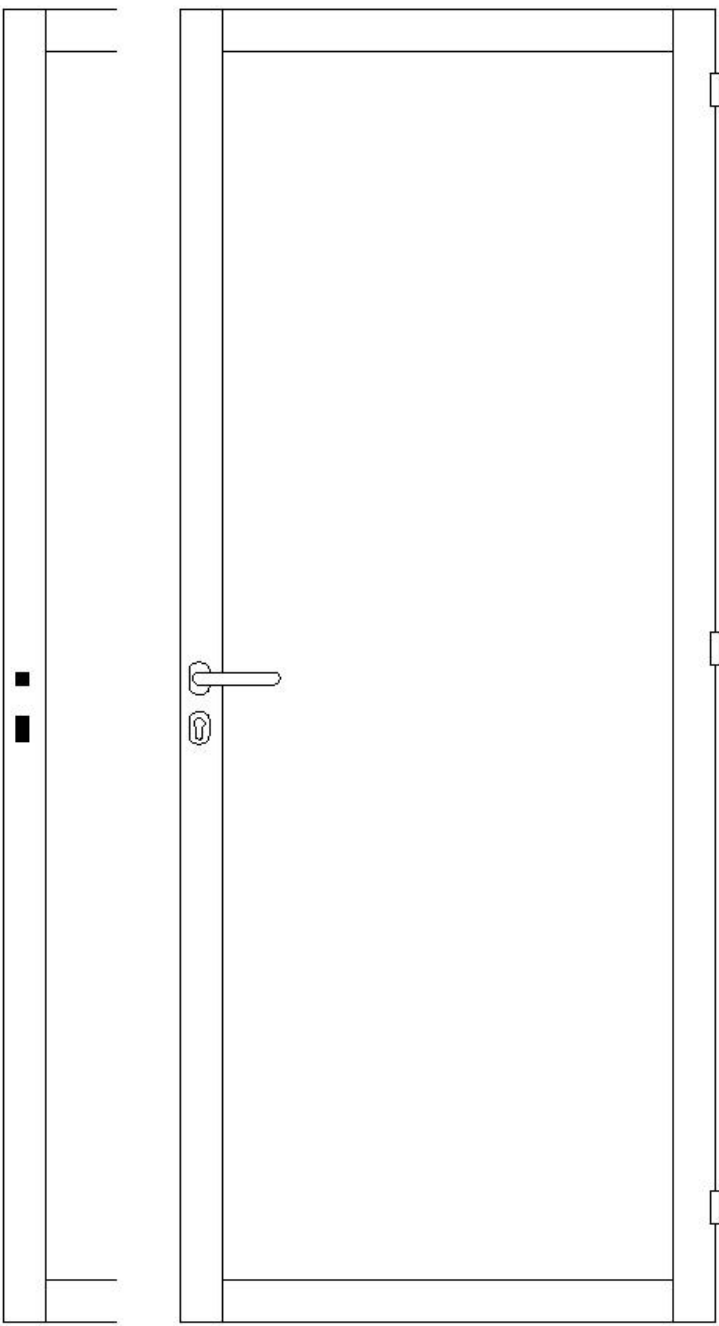

Dimension de vitrage 33.2 (6.8 mm) : 1940 X 730 mm

# Porte Opalys vitrée 33.2 coupe 90° Béquille double sur plaque

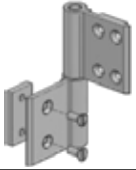

Usinage pour  
Serrure  
1 point  
SERPP65V  
Coffre de 41  
Entraxe 92  
Carré de 8 mm

# Porte Opalys vitrée 33.2 coupe 90° Béquille double et entrée de cylindre

	PP65V	
	JVP	
	Serrure SERPP65V largeur 41 entraxe 92 carré de 8	
	Cylindre Eu 35x35	
	Béquille double carré de 7	
	Entrée de cylindre	
	KIT1 PUA	
	PV5 B	
	Fourreau réducteur	

## Débit des montants et traverses (mm) :

Battant de service de 2040 X 830 :

PP65V : 2 fois 2040 (2C90°), 2 fois 700 (2C90°)

JPV : 2 fois 1945, 2 fois 700

Dimension de vitrage 33.2 (6.8 mm) : 1940 X 730 mm

# Porte Opalys vitrée 33.2 coupe 90° Béquille double et cache cylindre

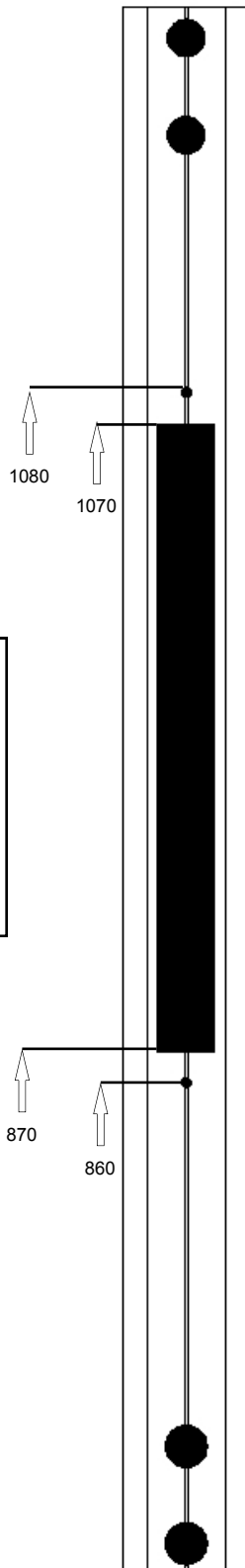



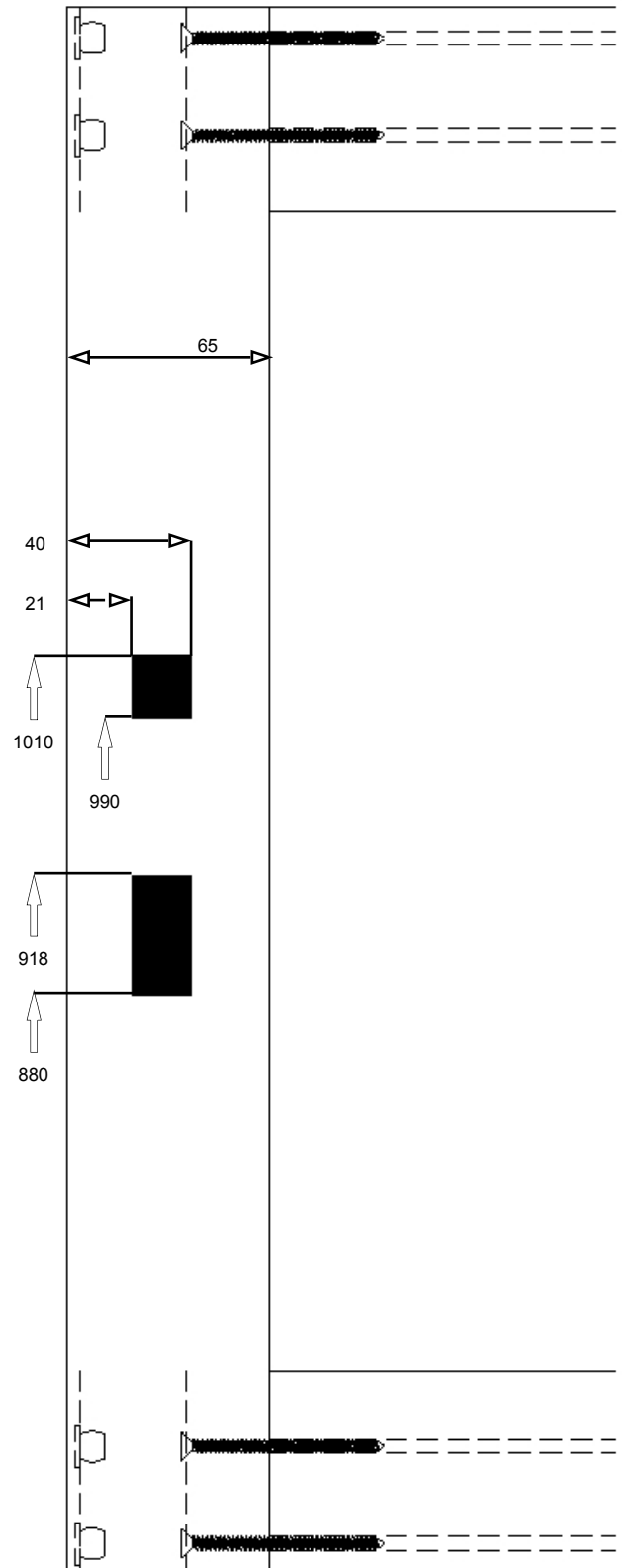



Usinage pour  
Serrure  
1 point  
SERPP65V  
Coffre de 41  
Entraxe 92  
Carré de 8 mm

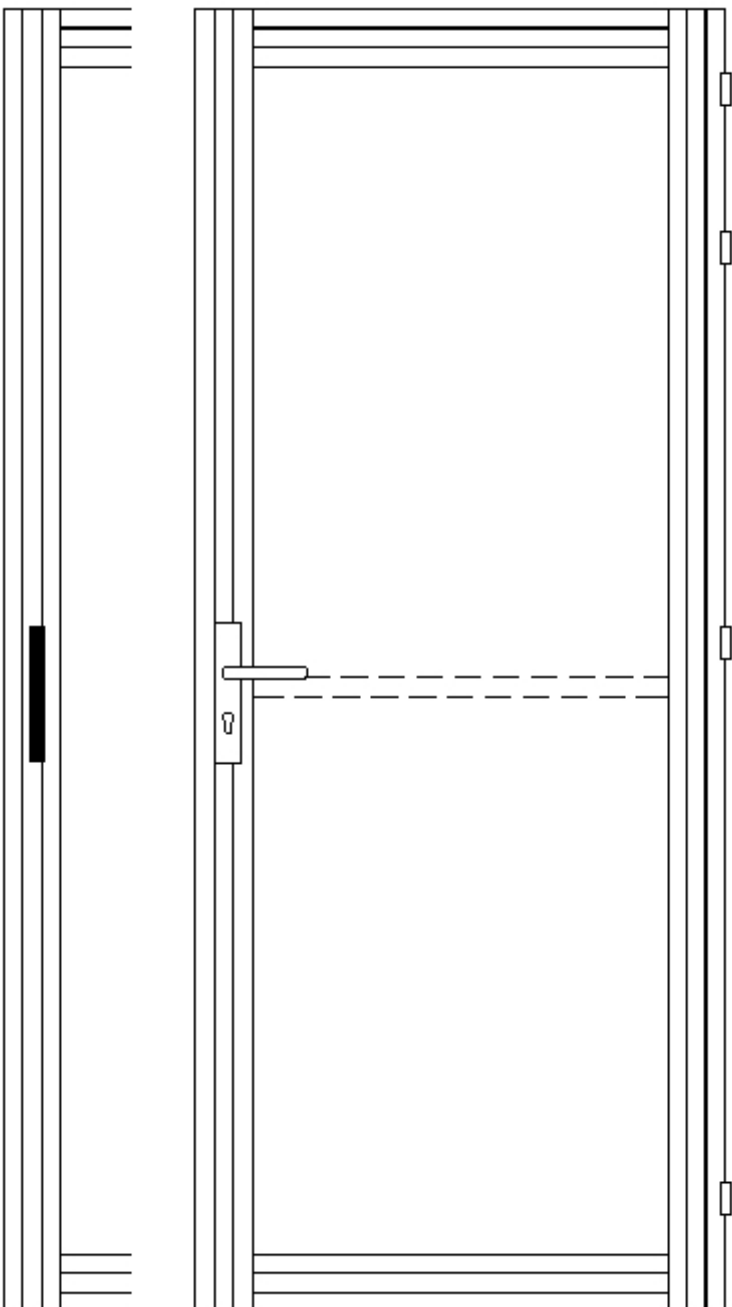
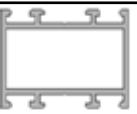

# Porte Cozy PP90 coupe 90°

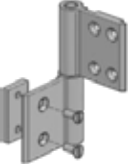
## Béquille double sur plaque

	PP90	
	TP40	
	Serrure SERPBBC axe à 50 entraxe 70 carré de 7	
	Cylindre Eu 35x35	
	Béquille double sur plaque entraxe 70 carré de 7	
	KIT1 PUA	
	PV5 B	

### Débit des montants et traverses (mm) :

Battant de service de 2040 X 830 :

PP90 : 2 fois 2040 (2C90°), 2 fois 650 (2C90°)

TP40 : 1 fois 650 (en cas de traverse intermédiaire )

Dimension de remplissage (sans traverse) : 1852 X 642 mm

# Porte Cozy PP90 coupe 90°



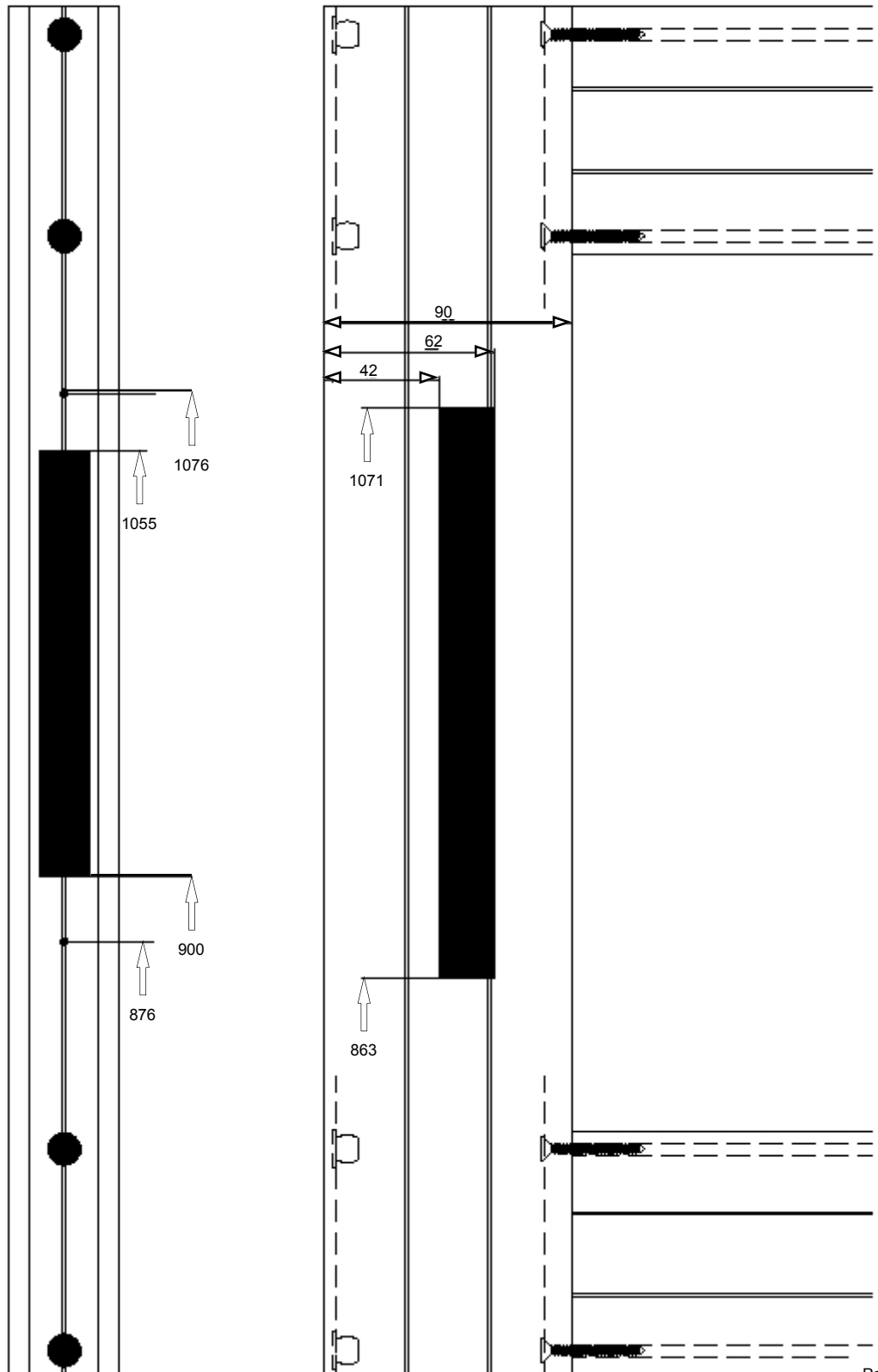
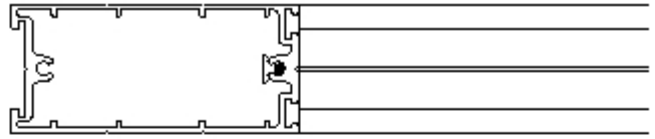



## Béquille double sur plaque

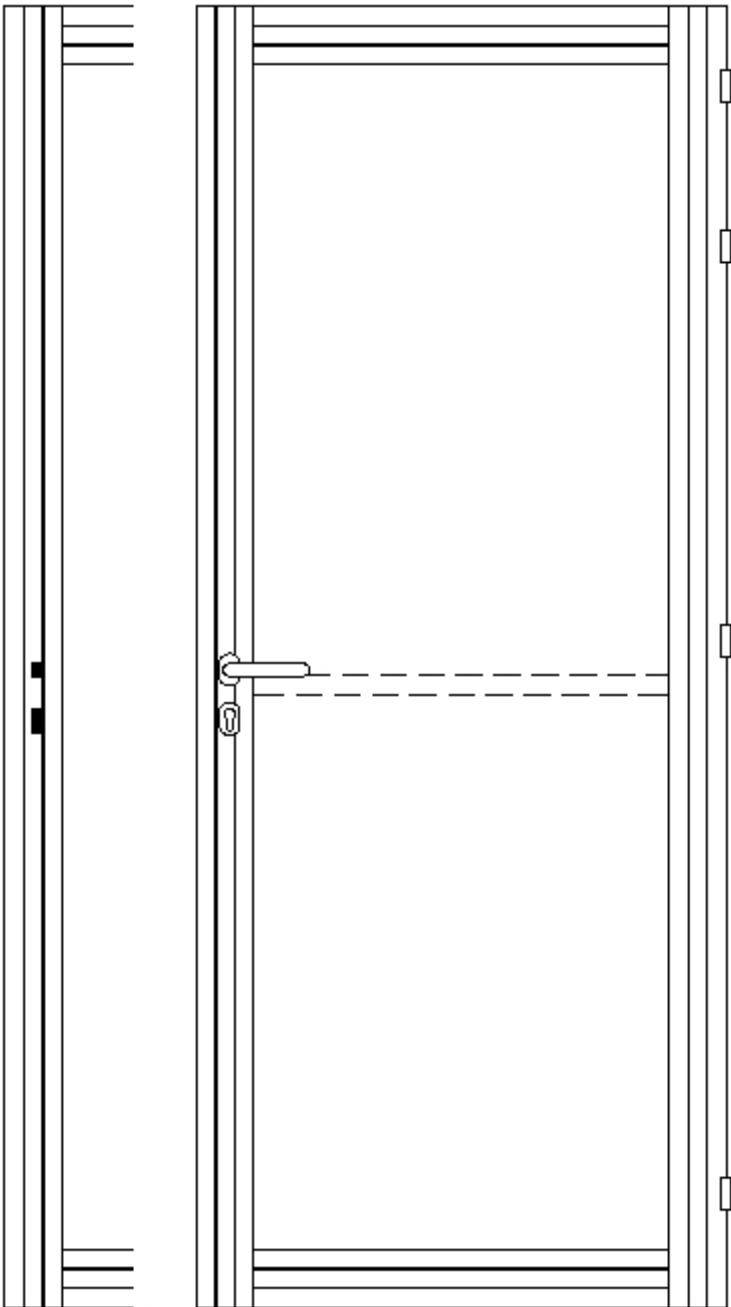
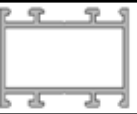

Usinage pour  
Serrure 1 point  
SERPBBC  
Axe à 50  
Entraxe 70  
Carré de 7 mm

# Porte Cozy PP90 coupe 90°

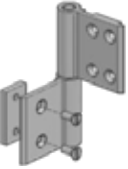
## Béquille double et entrée de cylindre

	PP90	
	TP40	
	Serrure SERPBBC axe à 50 entraxe 70 carré de 7	
	Cylindre Eu 35x35	
	Béquille double carré de 7	
	Entrée de cylindre	
	KIT1 PUA	
	PV5 B	

### Débit des montants et traverses (mm) :

Battant de service de 2040 X 830 :

PP90 : 2 fois 2040 (2C90°), 2 fois 650 (2C90°)

TP40 : 1 fois 650 (en cas de traverse intermédiaire )

Dimension de remplissage (sans traverse) : 1852 X 642 mm





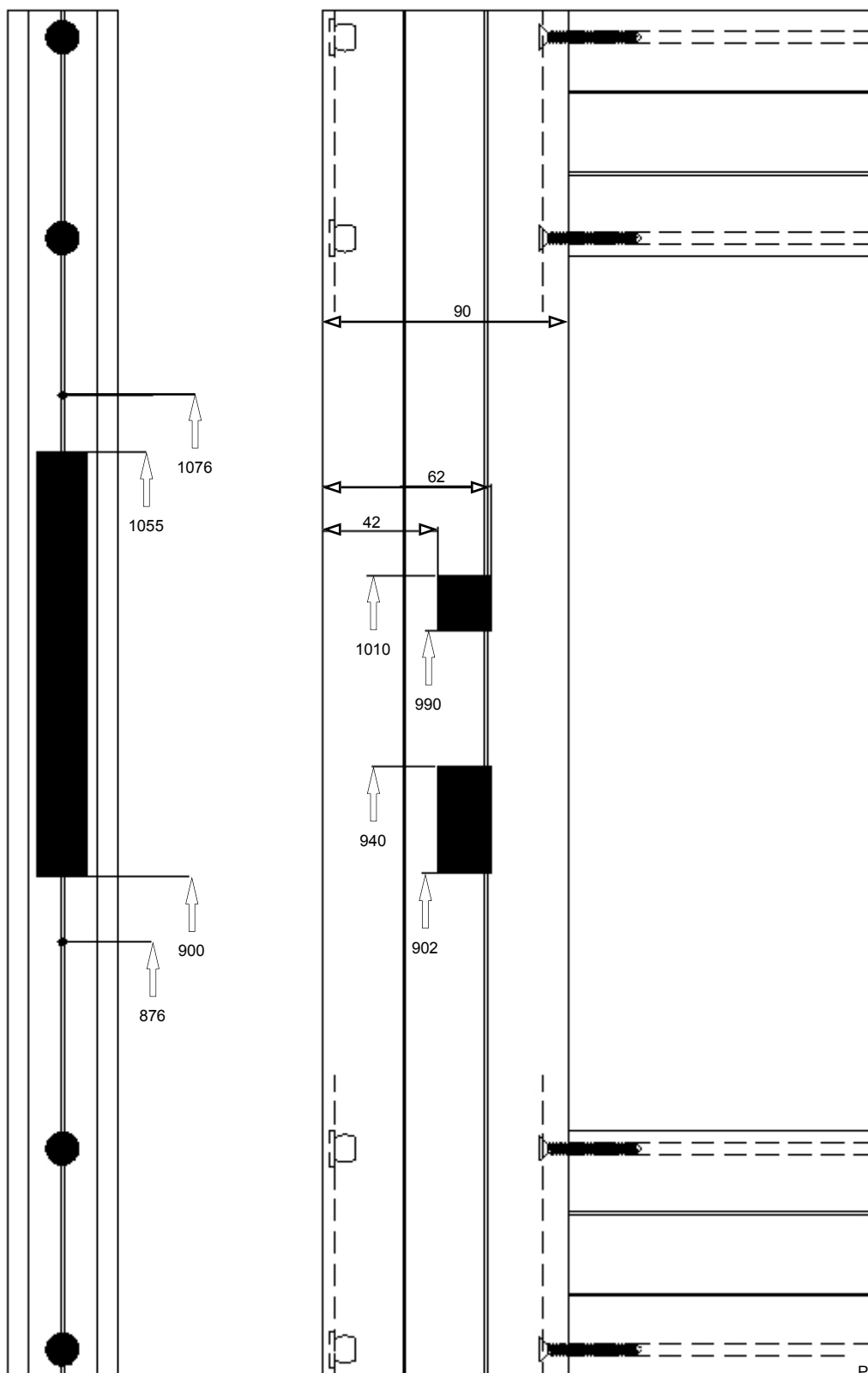
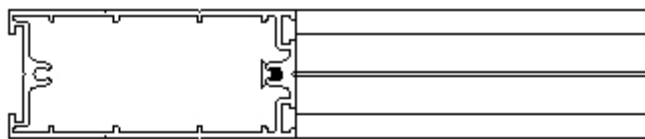

# Porte Cozy PP90 coupe 90°

## Béquille double et entrée de cylindre

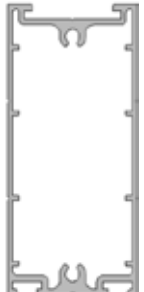
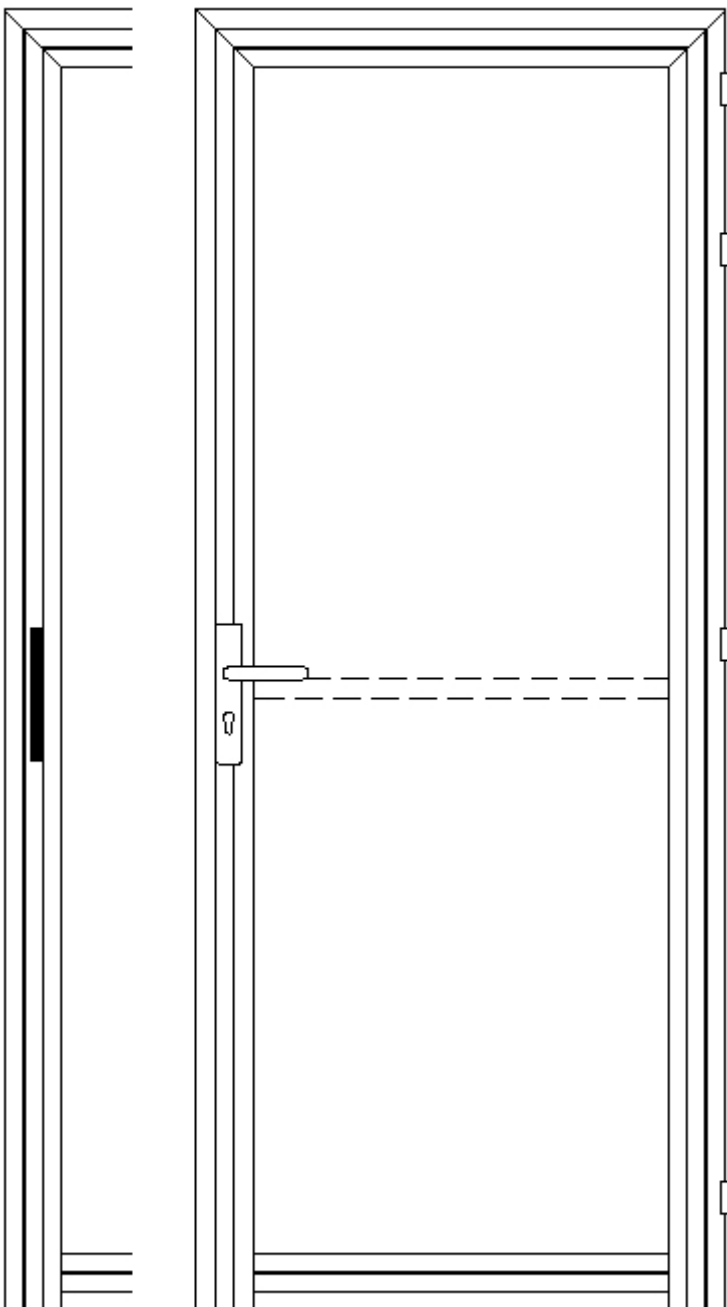

Usinage pour  
Serrure 1 point  
SERPBBC  
Axe à 50  
Entraxe 70  
Carré de 7 mm

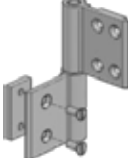
# Porte Cozy PP90 coupe 45° Béquille double sur plaque

	PP90	
	TP40	
	Serrure SERPBBC axe à 50 entraxe 70 carré de 7	
	Cylindre Eu 35x35	
	Béquille double sur plaque entraxe 70 carré de 7	
	KIT1 PUA	
	PV5 B	

## Débit des montants et traverses (mm) :

Battant de service de 2040 X 830 :

PP90 + JCP : 2 fois 2040 (1C45°), 1 fois 830 (2C45°), 1 fois 650 (2C90°)

TP40 : 1 fois 650 (en cas de traverse intermédiaire )

Dimension de remplissage (sans traverse) : 1852 X 642 mm

# Porte Cozy PP90 coupe 45° Béquille double sur plaque



JCP

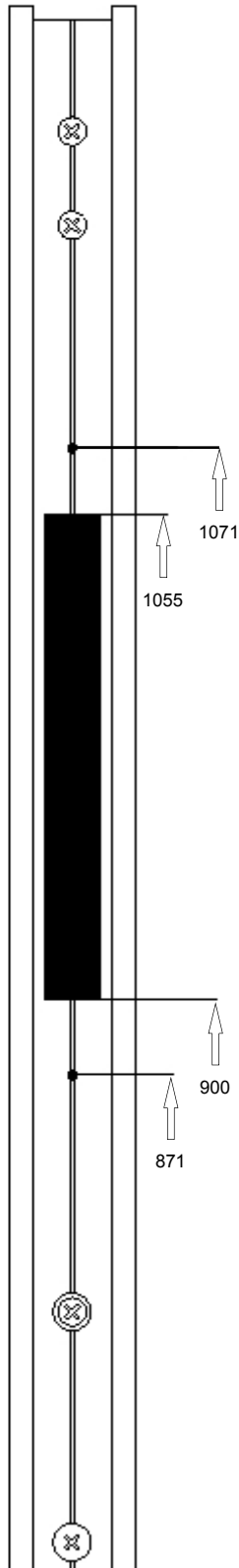

Usinage pour  
Serrure 1 point  
SERPBBC  
Axe à 50  
Entraxe 70  
Carré de 7 mm





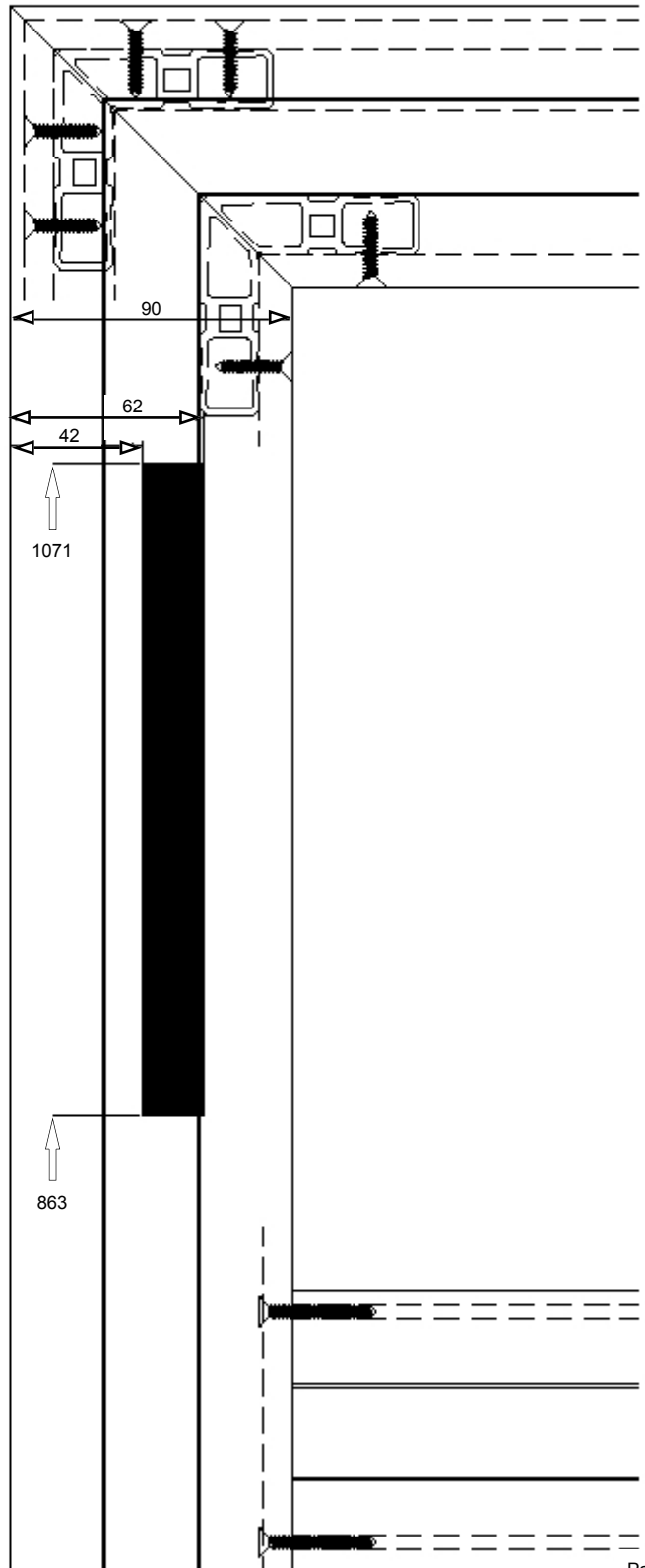
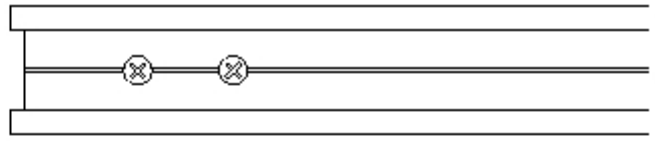



JCP

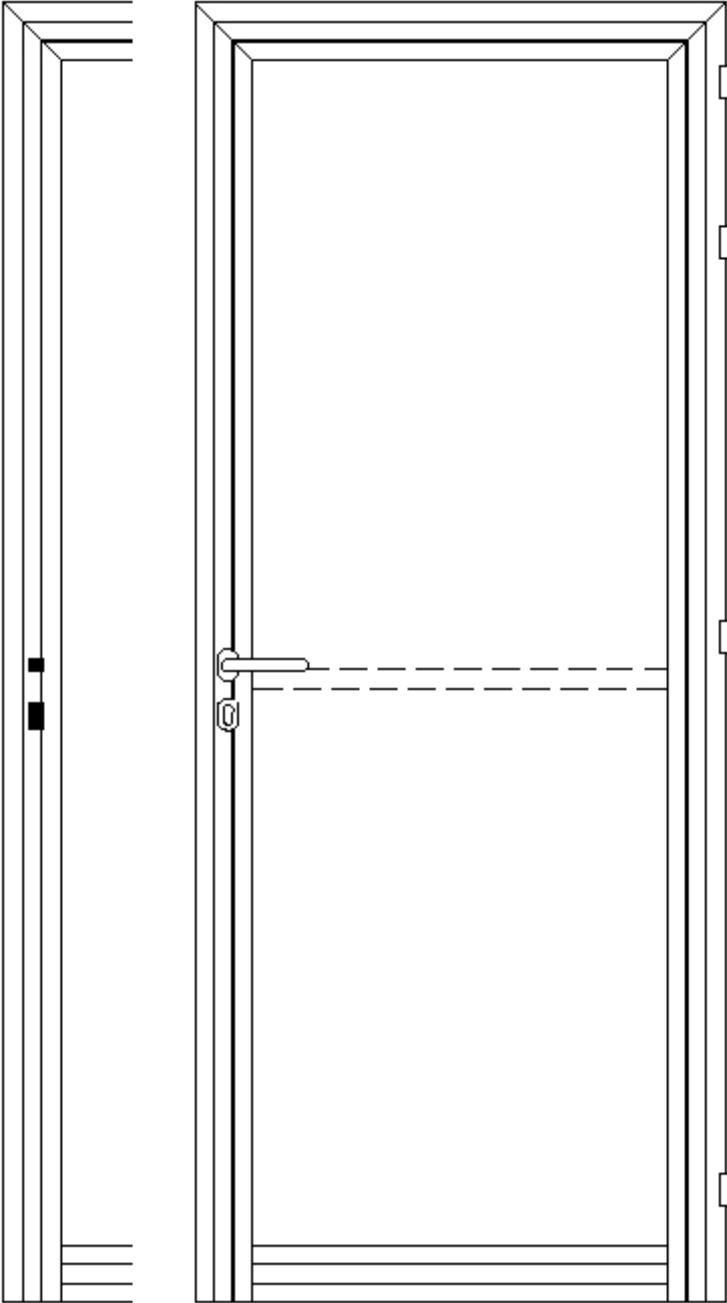
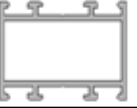

# Porte Cozy PP90 coupe 45°

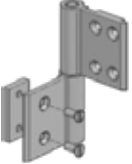
## Béquille double et entrée de cylindre

	PP90	
	TP40	
	Serrure SERPBBC axe à 50 entraxe 70 carré de 7	
	Cylindre Eu 35x35	
	Béquille double carré de 7	
	Entrée de cylindre	
	KIT1 PUA	
	PV5 B	

### Débit des montants et traverses (mm) :

Battant de service de 2040 X 830 :

PP90 + JCP : 2 fois 2040 (1C45°), 1 fois 830 (2C45°), 1 fois 650 (2C90°)

TP40 : 1 fois 650 (en cas de traverse intermédiaire )

Dimension de remplissage (sans traverse) : 1852 X 642 mm

# Porte Cozy PP90 coupe 45°

## Béquille double et entrée de cylindre



JCP

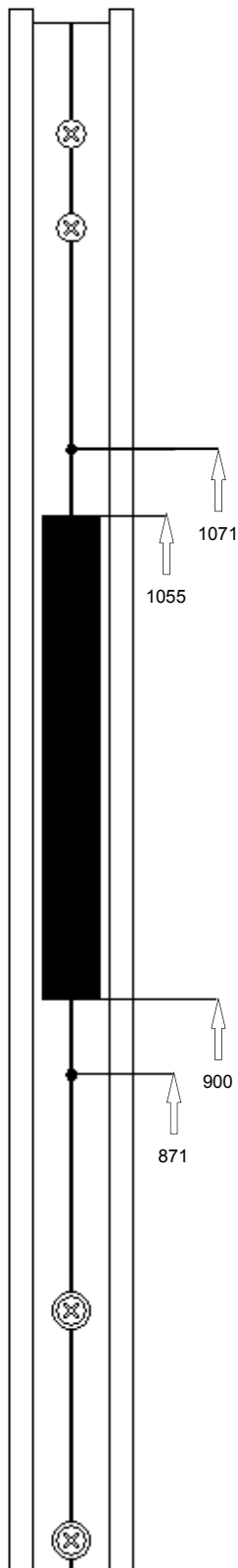





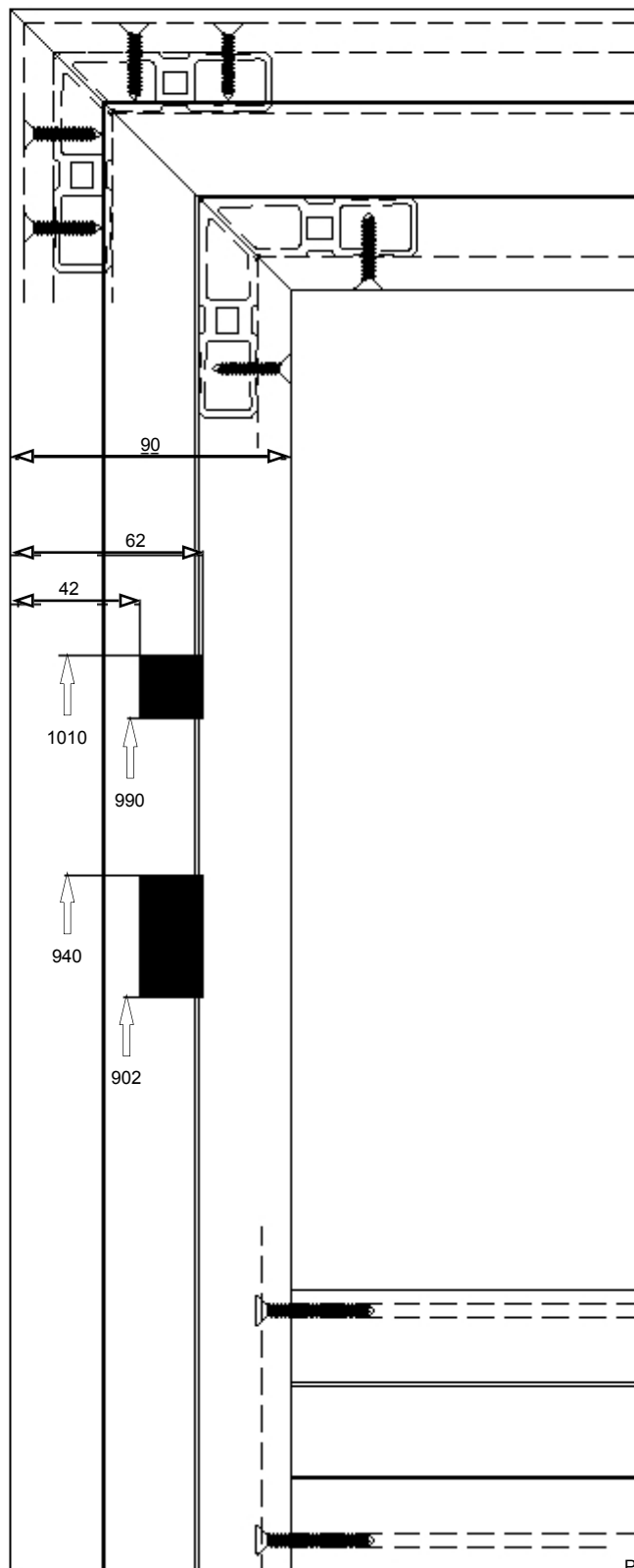
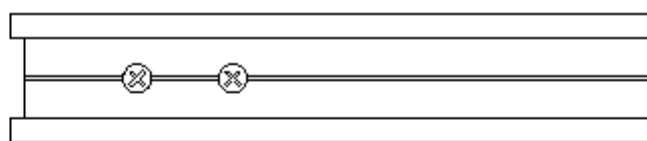

Usinage pour  
Serrure 1 point  
SERPBBC  
Axe à 50  
Entraxe 70  
Carré de 7 mm

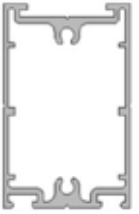
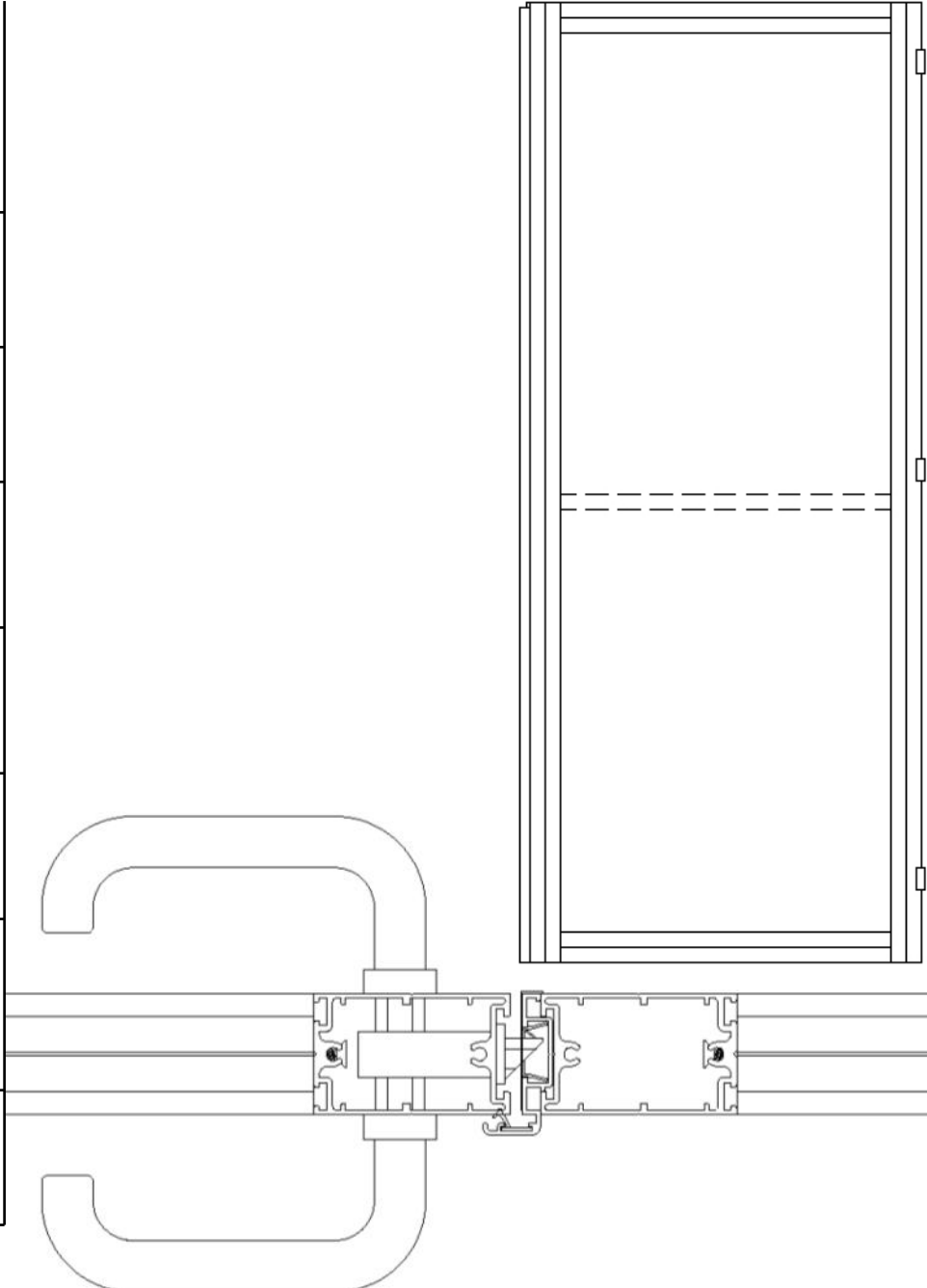

JCP

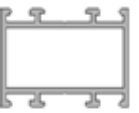

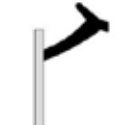
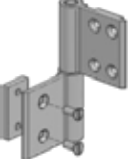
# Semi fixe de porte double Golf PP65 coupe 90°

	PP65	
	FP40	
	TP40	
	Gâche inox	
	VFP Verrou de frappe	
	JFP Joint de frappe	
	KIT1 PUA	
	PV5 B	

## Débit des montants et traverses (mm) :

Battant semi - fixe de 2040 X 836 :

PP65 : 2 fois 2040 (2C90°), 2 fois 700 (2C90°)







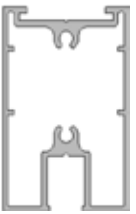
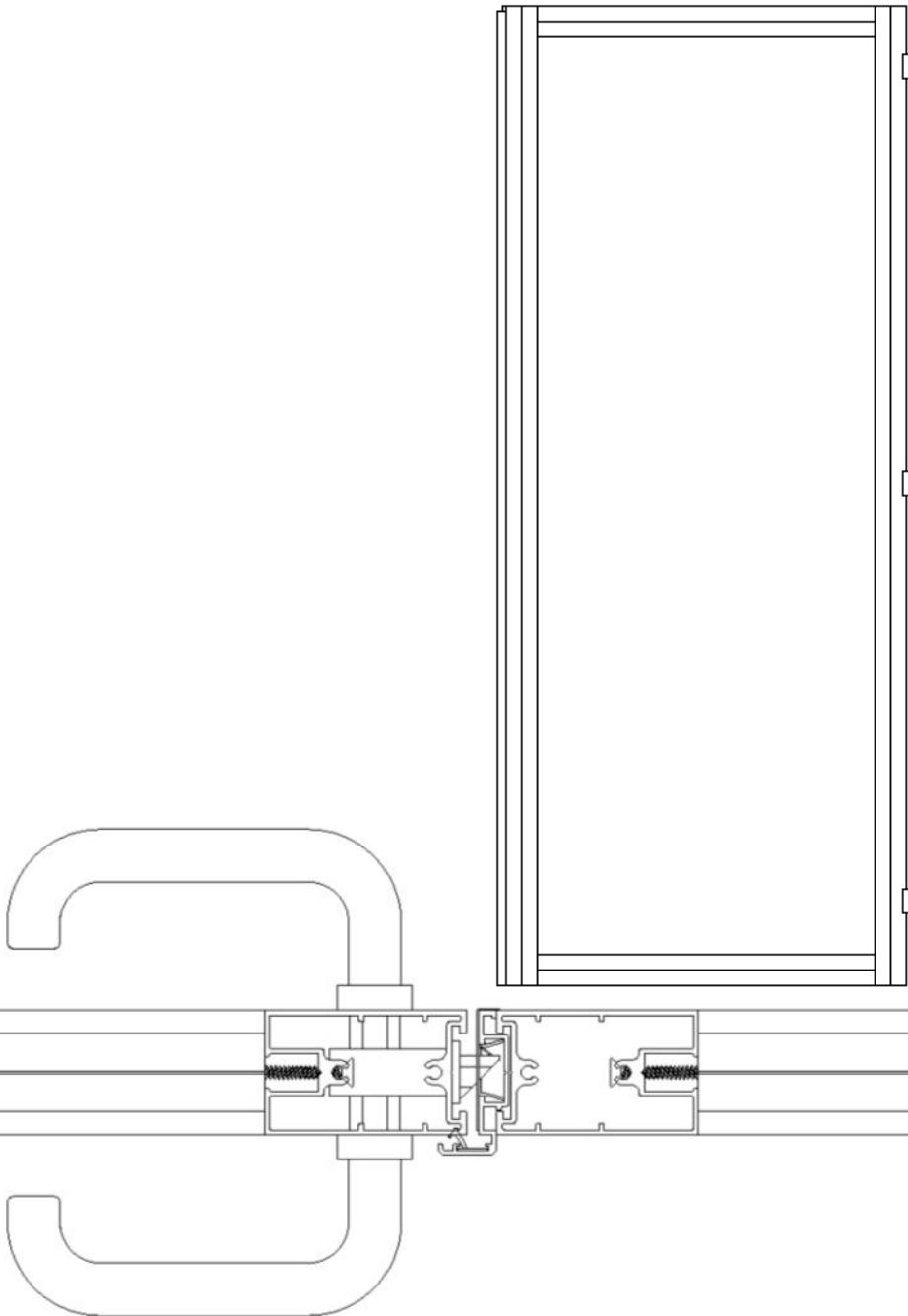

FP40 : 1 fois 2040 (2C90°)

TP40 : 1 fois 700 (en cas de traverse intermédiaire )

Dimension de remplissage (sans traverse) : 1902 X 692 mm

# Semi fixe de porte double Opalys

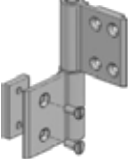
## Vitrée 33.2 PP65 V coupe 90°

	PP65 V	
	JVP	
	FP40	
	Gâche inox	
	VFP Verrou de frappe	
	JFP Joint de frappe	
	KIT1 PUA	
	PV5 B	

### Débit des montants et traverses (mm) :

Battant semi - fixe de 2040 X 836 :







PP65V : 2 fois 2040 (2C90°), 2 fois 700 (2C90°)

FP40 : 1 fois 2040 (2C90°)

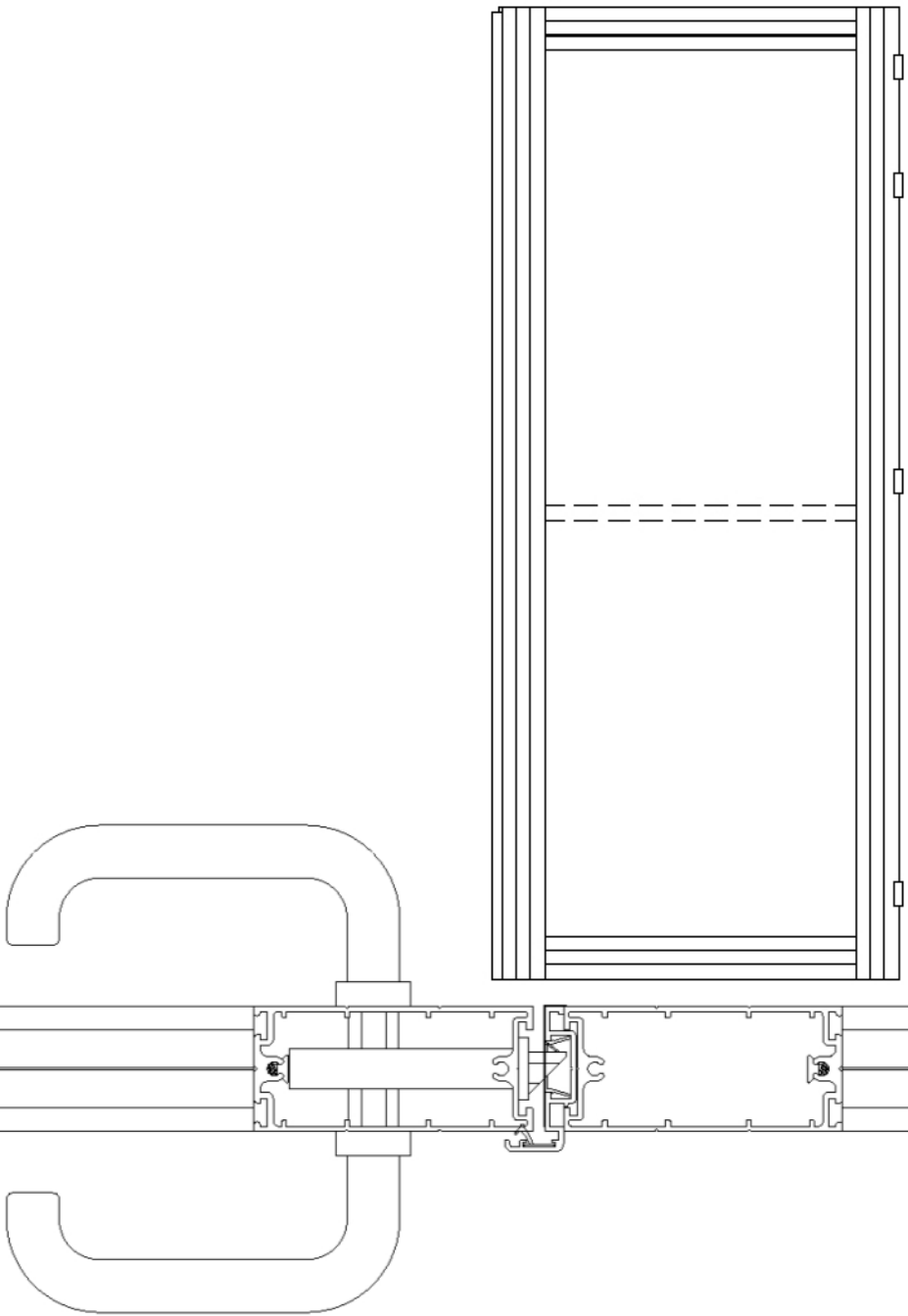
JVP : 2 fois 1945, 2 fois 600

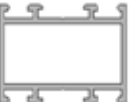
Dimension de vitrage 33.2 (8.8 mm) : 1940 X 730 mm

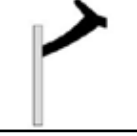
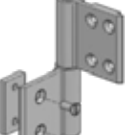
# Semi fixe de porte double Cozy PP90 coupe 90°

	PP90	
	FP40	
	TP40	
	Gâche inox	
	VFP Verrou de frappe	
	JFP Joint de frappe	
	KIT1 PUA	
	PV5 B	

## Débit des montants et traverses (mm) :

Battant semi - fixe de 2040 X 836 :

PP90 : 2 fois 2040 (2C90°), 2 fois 650 (2C90°)

TP40 : 1 fois 650 (en cas de traverse intermédiaire )

FP40 : 1 fois 2040 (2C90°)

Dimension de remplissage (sans traverse) : 1852 X 642 mm

# Double vitrage sur porte Cozy PP90 + AV65 / 2

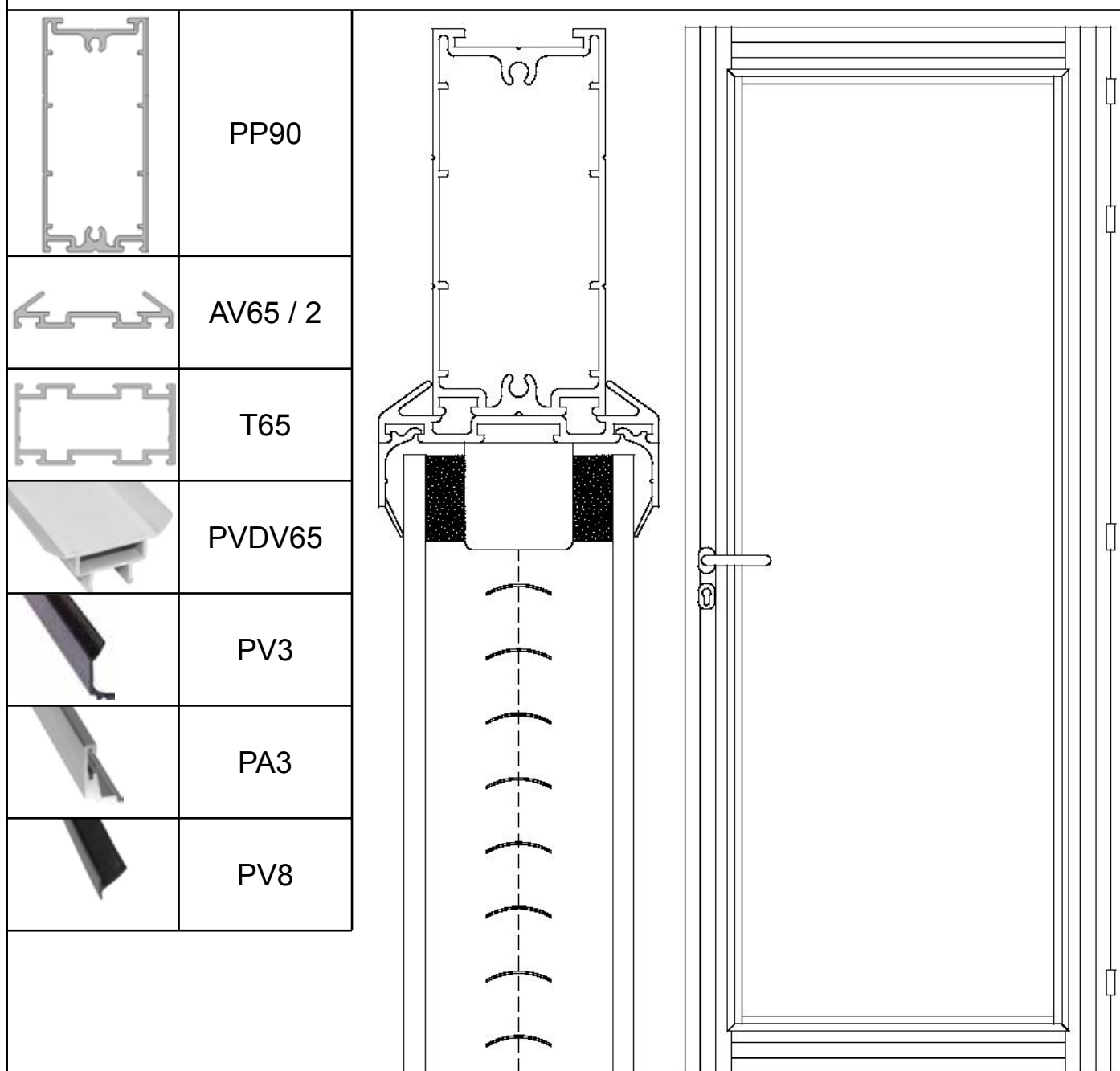

## Débit des montants et traverses AV65 / 2 et T65 :

Battant PP90 de 2040 X 830 :

AV65 / 2 : 2 fois 1860 mm (2C45°), 2 fois 650 mm (2C45°)

T65 : 1 fois 637.5 mm (en cas de traverse intermédiaire )

Dimension de remplissage (sans traverse) : 1840 X 630 mm

Dimension du store (sans traverse) : 1822 X 597 mm

# Oculus sur porte bois

## Double vitrage avec AV65 / 2

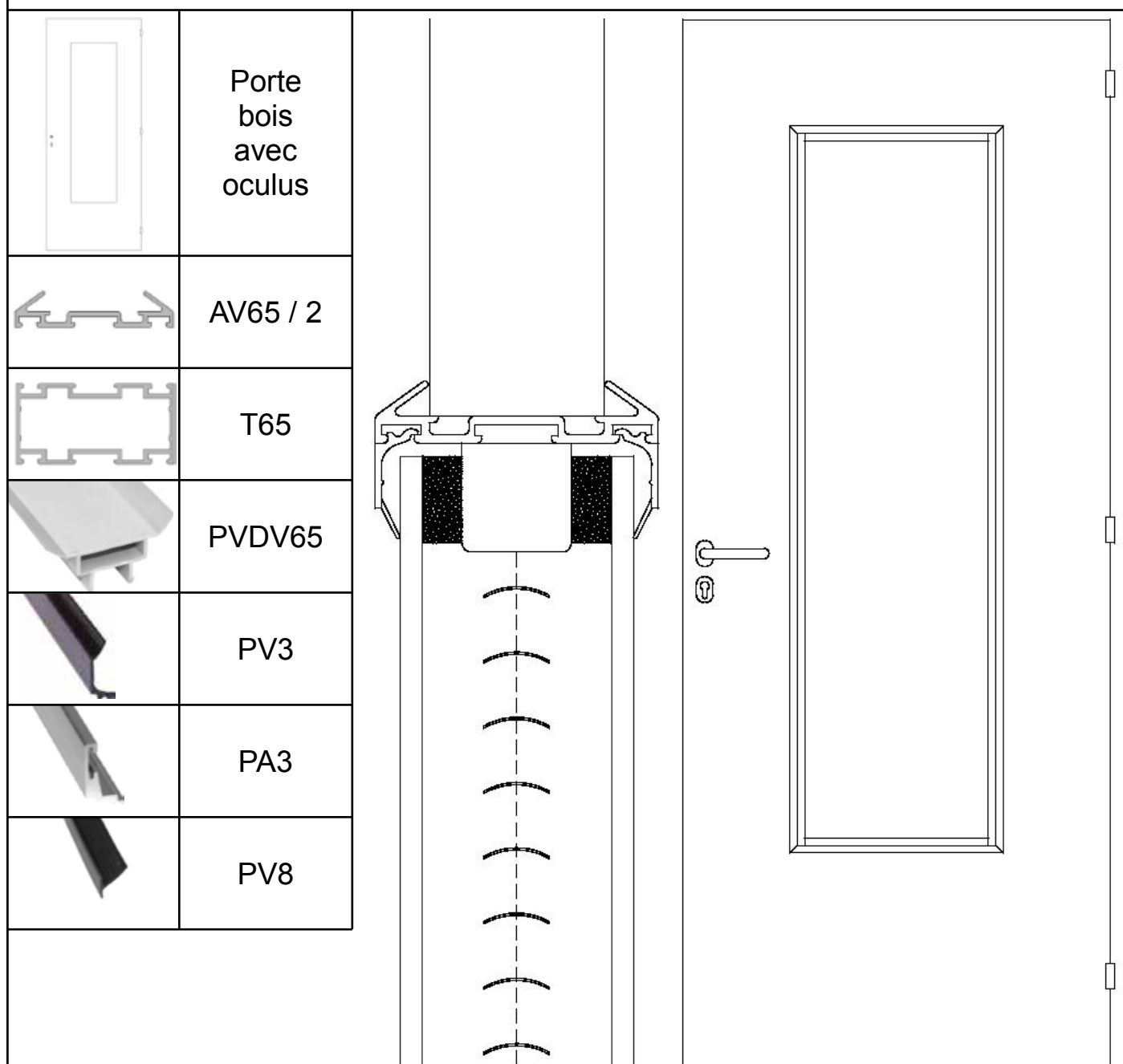

### Débit des montants et traverses AV65 / 2 et T65 :

Dimension standard de l'oculus (pour une porte bois de 2040 X 830) : 1400 X 400

AV65 / 2 : 2 fois 1400 mm (2C45°), 2 fois 400 mm (2C45°)

T65 : 1 fois 387.5 mm (en cas de traverse intermédiaire)

Dimension de remplissage (sans traverse) : 1379 X 379 mm

Dimension du store (sans traverse) : 1362 X 347 mm

# Porte coulissante Glide sur rail acier

## Serrure 1 point haut à tringle ronde

	PP90
	TP40
	U de 40 X 25
	Serrure 1 point SER2PTTR Coffre de 41
	Cylindre Eu 35x35
	Gâche haute
	Guide bas
	Poignée de tirage nylon
	Entrée de cylindre nylon
	Joint brosse autocollant

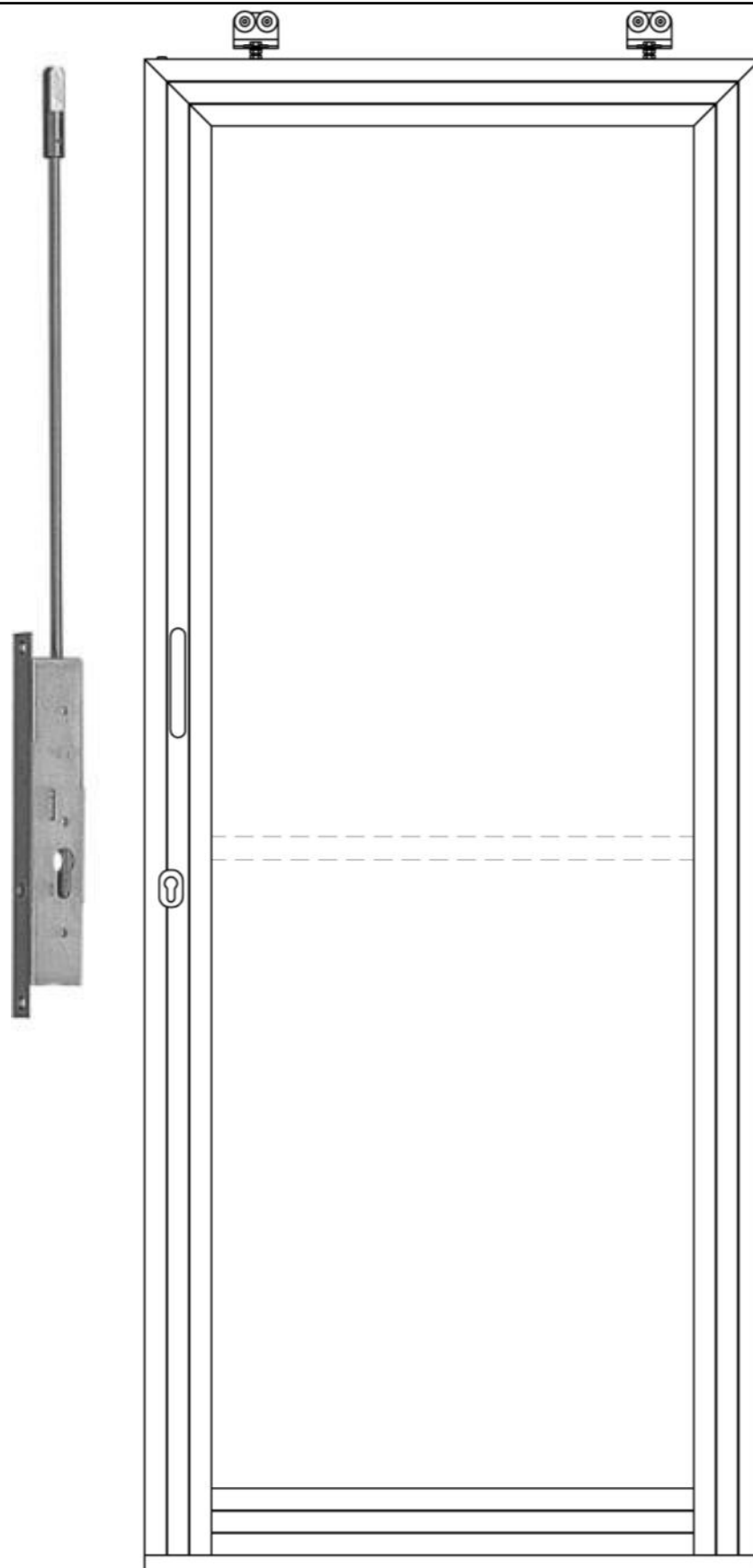

# Porte coulissante Glide sur rail acier

## Serrure 1 point haut à tringle ronde

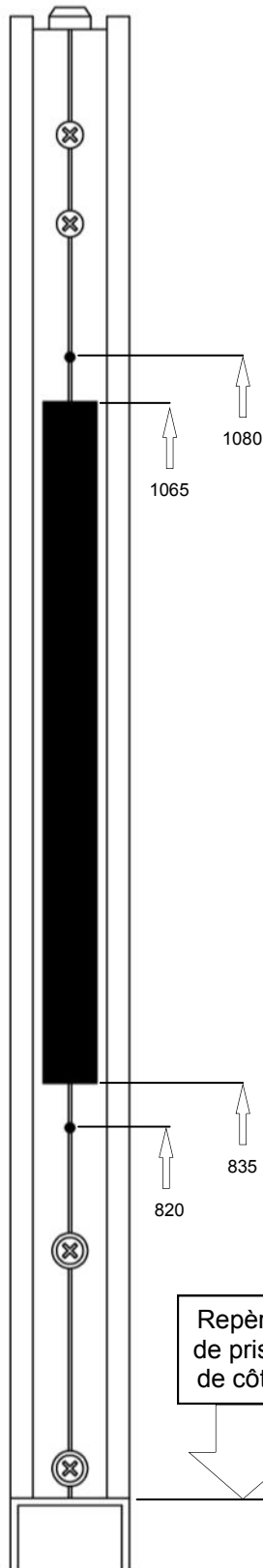
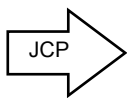

Usinage pour  
Serrure 1 point  
à tringle ronde  
SER2PTTR  
coffre de 41 mm  
Ref :2253.41.0

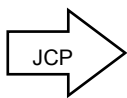

Repère  
de prise  
de côte

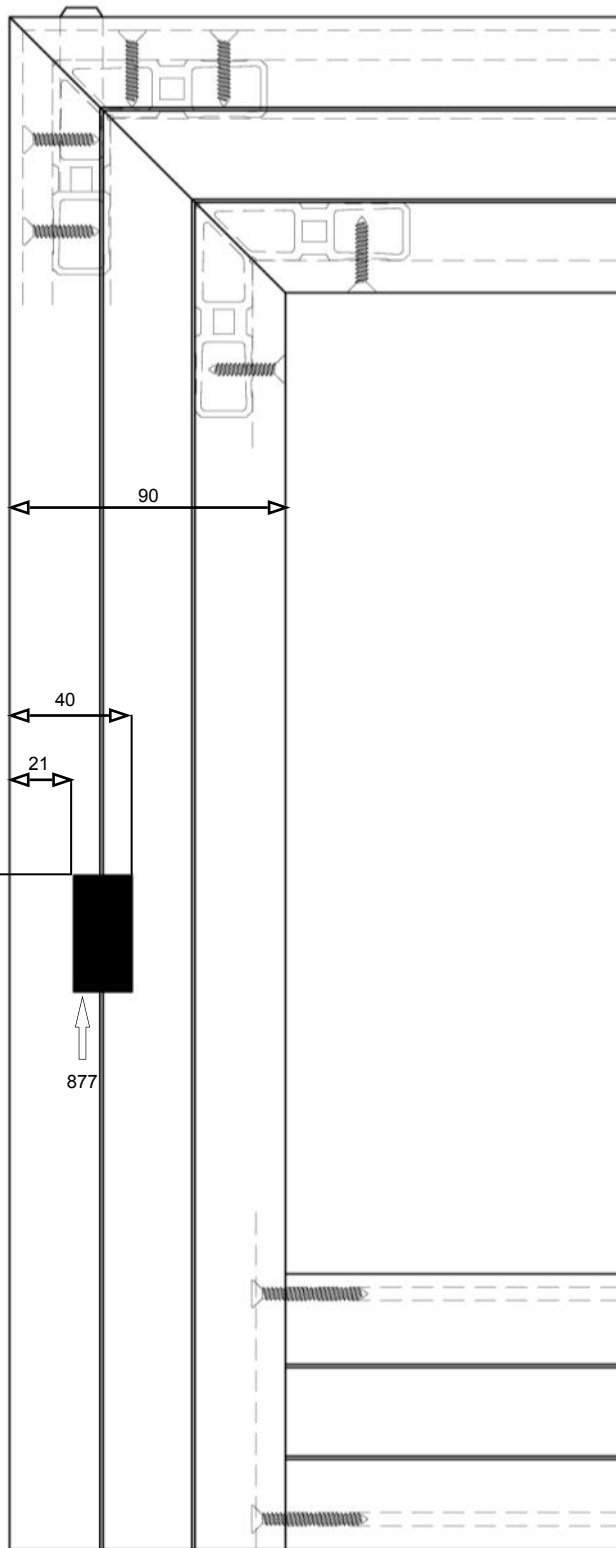
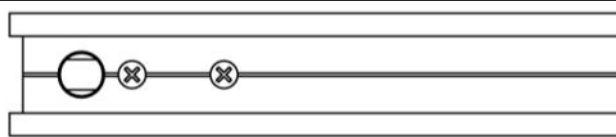

U de 40 X 25

# Porte coulissante Glide sur Série 65

## Serrure 1 point haut à tringle ronde

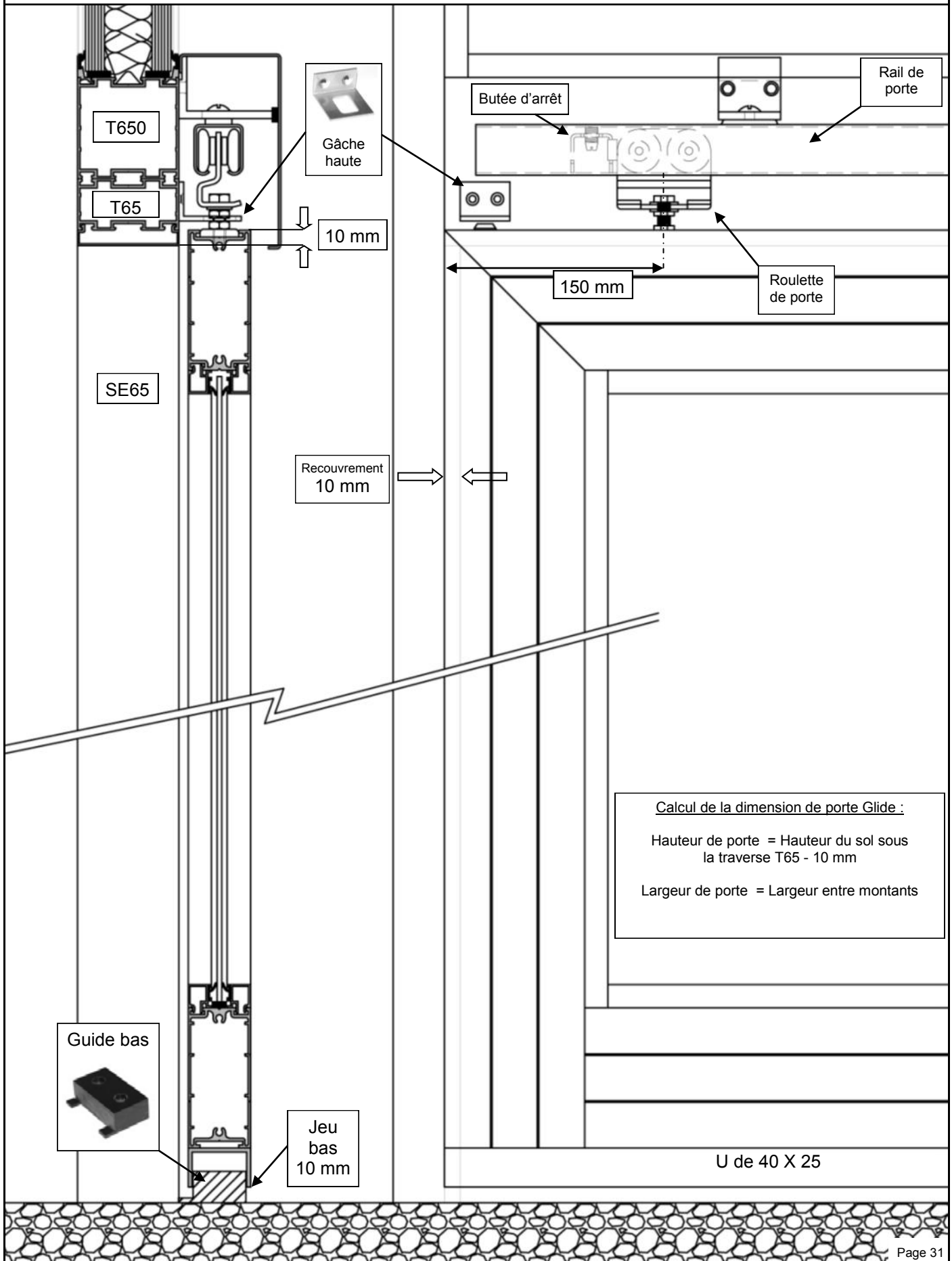

# Porte coulissante Club

## Serrure 1 point haut

	PP90
	TP40
	U de 40 X 25
	Serrure 1 point SER2PTTR Coffre de 41
	Cylindre Eu 35x35
	Butée d'arrêt
	Guide bas
	Poignée de tirage nylon
	Entrée de cylindre nylon
	Joint brosse autocollant
	Anti- dégondage

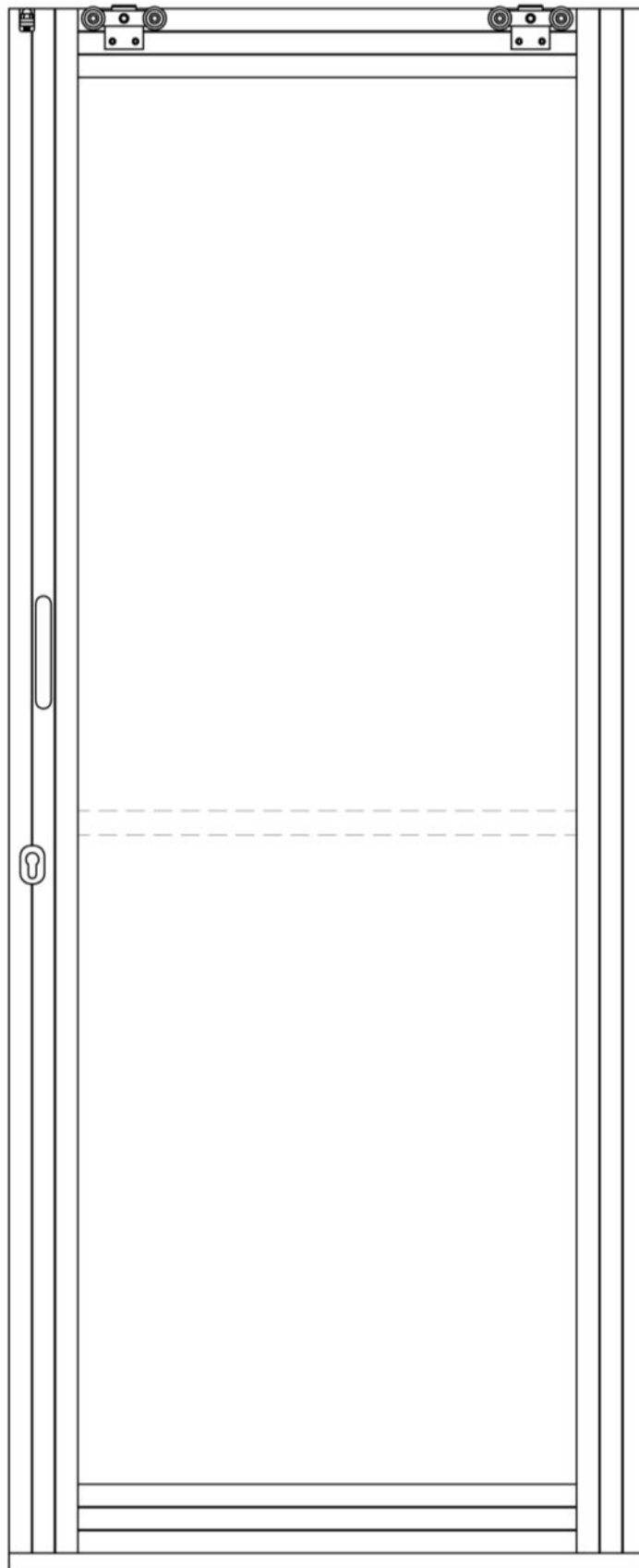

# Porte coulissante Club Serrure 1 point haut

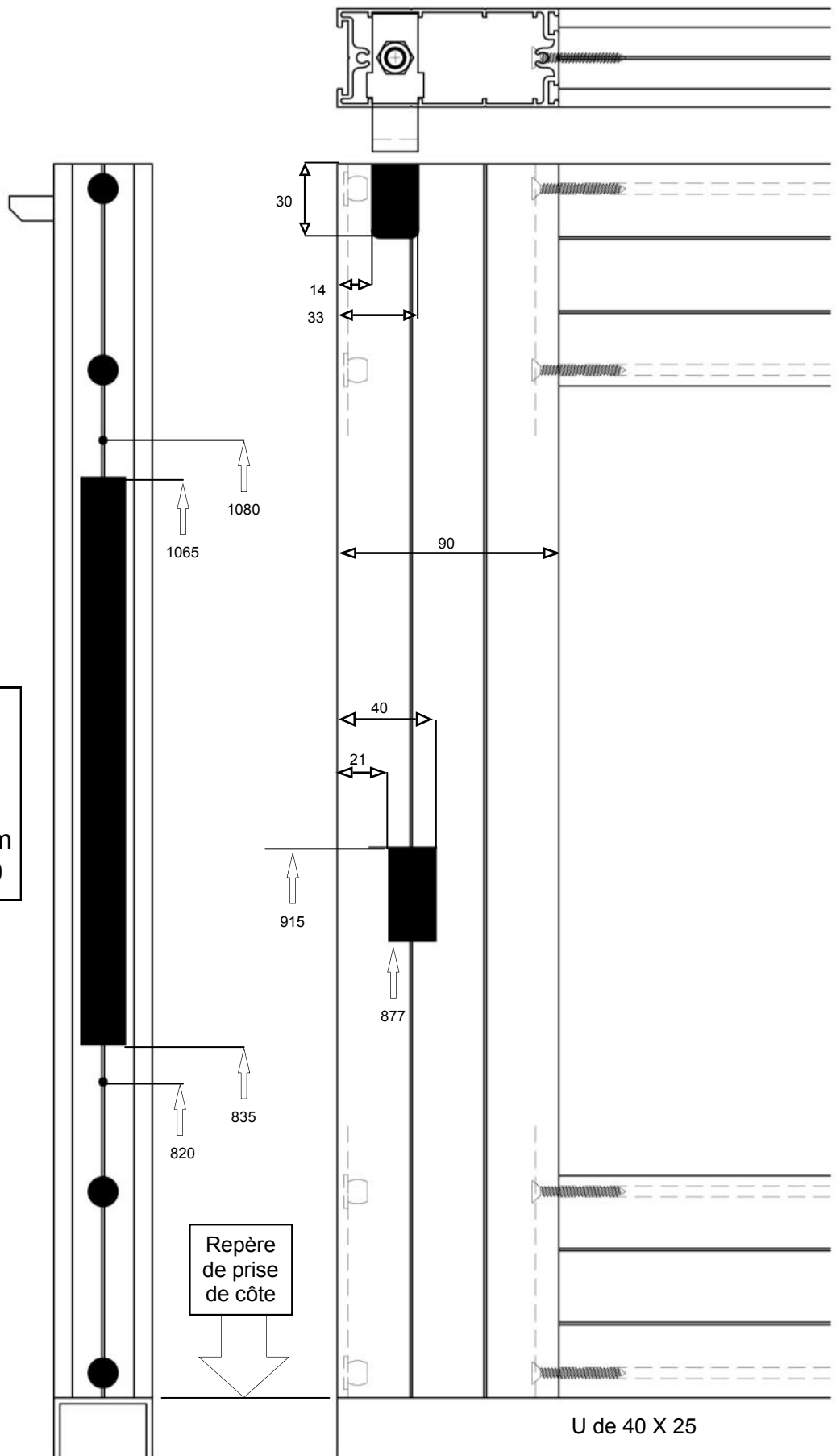

Usinage pour  
serrure 1 point  
à tringle ronde  
SER2PTTR  
coffre de 41 mm  
Ref :2253.41.0

Repère  
de prise  
de côte

U de 40 X 25

# Porte coulissante Club

## Serrure 1 point haut

	PP90
	TP40
	U de 40 X 25
	Serrure 1 point SER2PTTR Coffre de 41
	Cylindre Eu 35x35
	Butée d'arrêt
	Guide bas
	Poignée coquille inox
	Entrée de cylindre inox
	Joint brosse autocollant
	Anti- dégondage

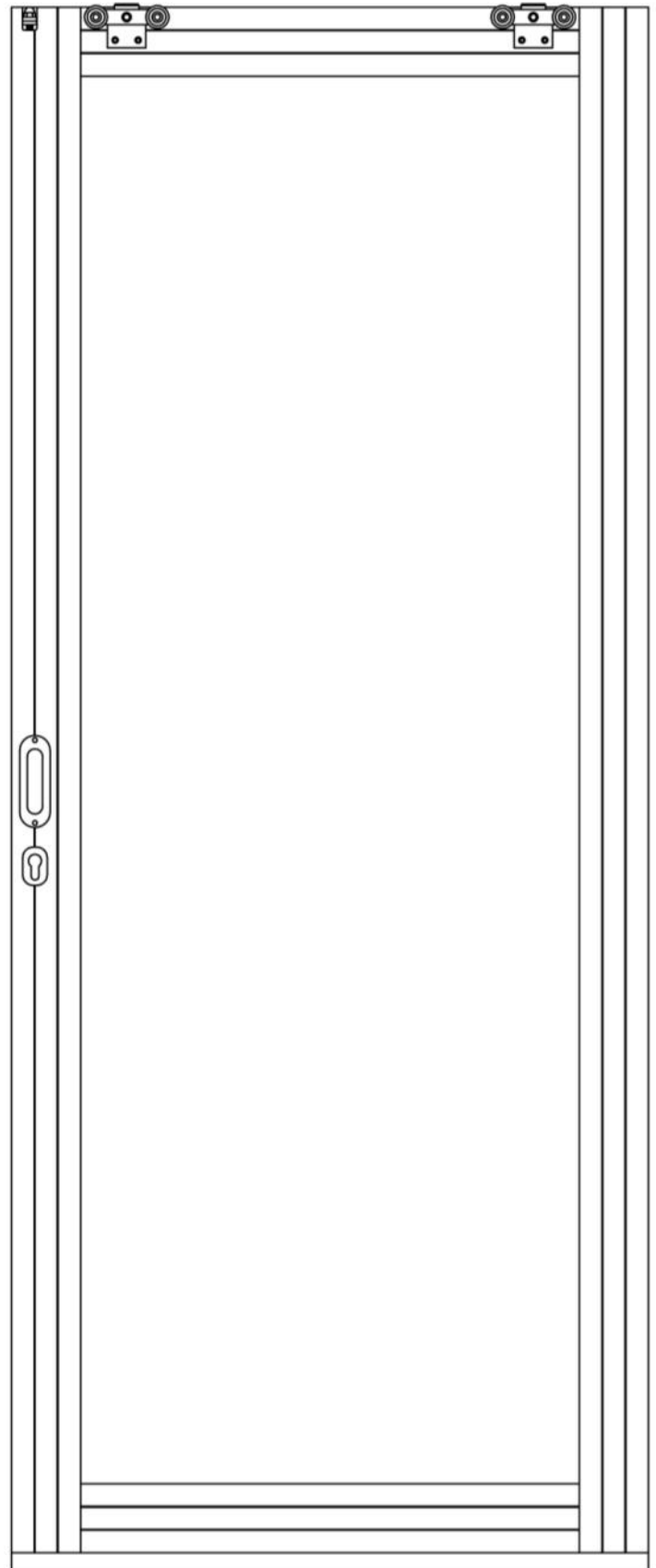

# Porte coulissante Club Serrure 1 point haut

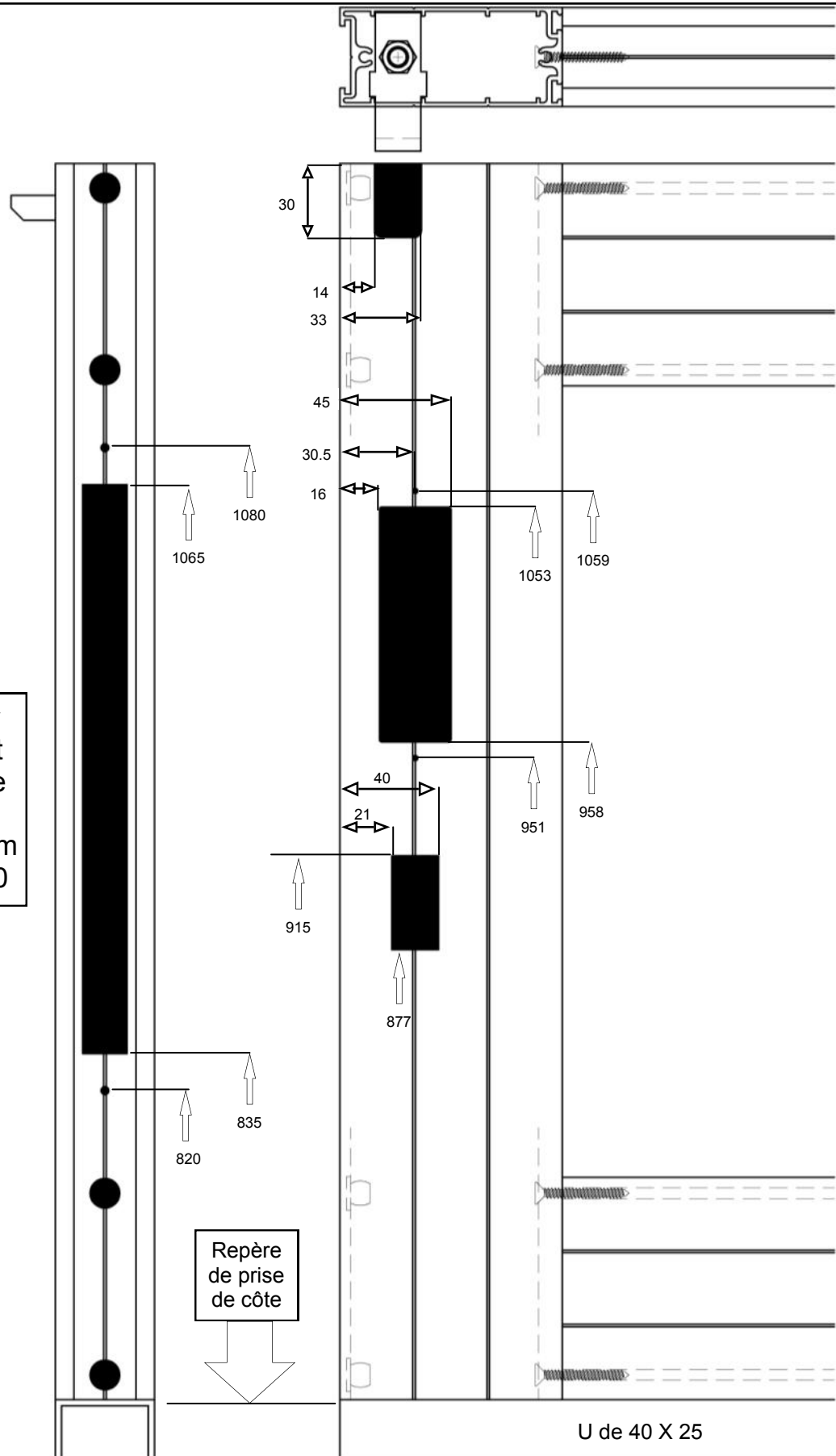

Usinage pour  
serrure 1 point  
à tringle ronde  
SER2PTTR  
coffre de 41 mm  
Ref :2253.41.0

Repère  
de prise  
de côte

U de 40 X 25

# Porte coulissante Club sur cloison Série 65 Serrure 1 point haut

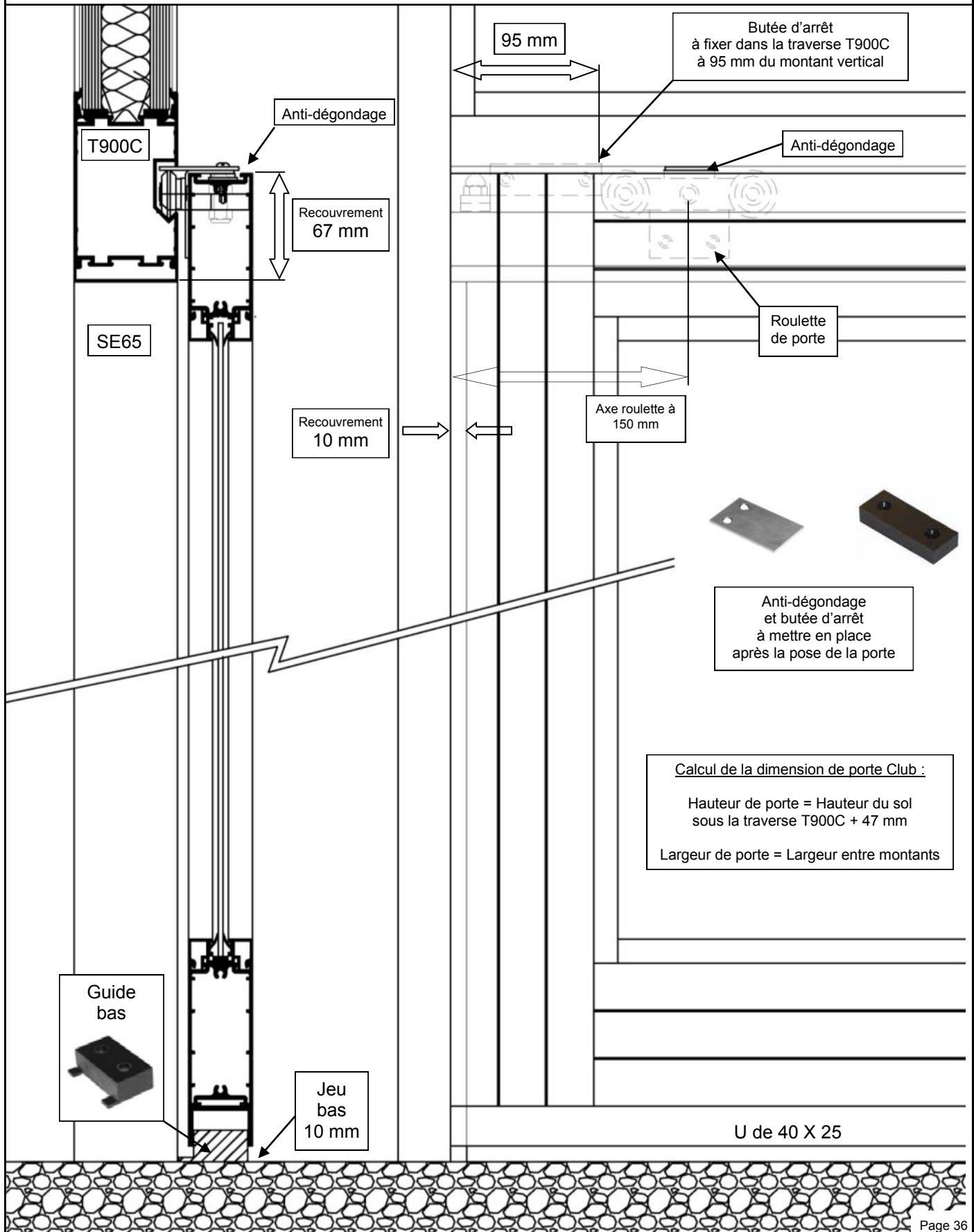

# Porte coulissante Club sur cloison Mistral 85 Serrure 1 point haut

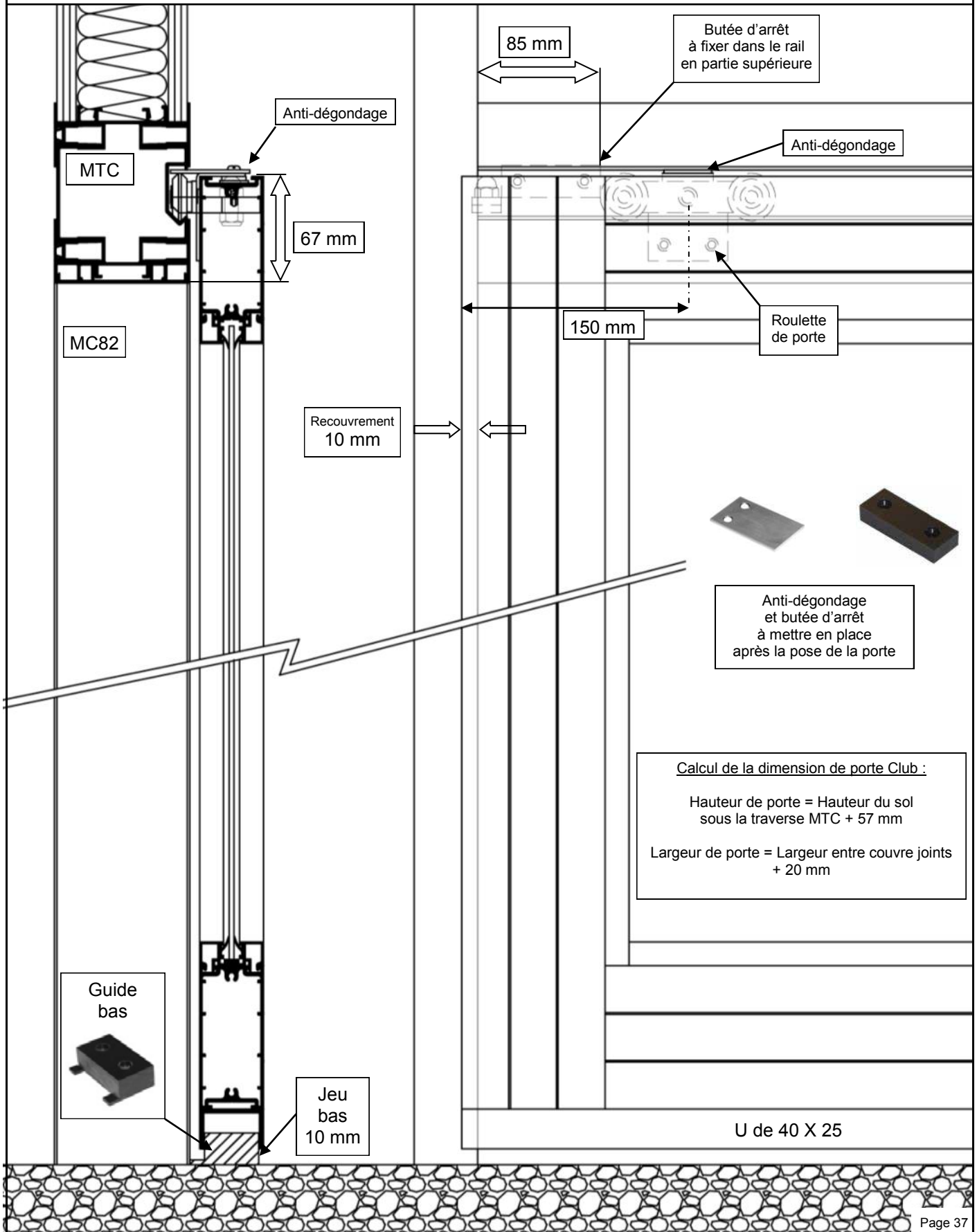

# Porte coulissante Lounge vitrée 33.2

## Serrure 1 point haut

	PP65V
	U de 40 X 25
	JVP
	Serrure 1 point SER2PTTR Coffre de 41
	Cylindre Eu 35x35
	Butée d'arrêt
	Guide bas
	Poignée de tirage nylon
	Entrée de cylindre nylon
	Joint brosse autocollant
	Anti- dégondage

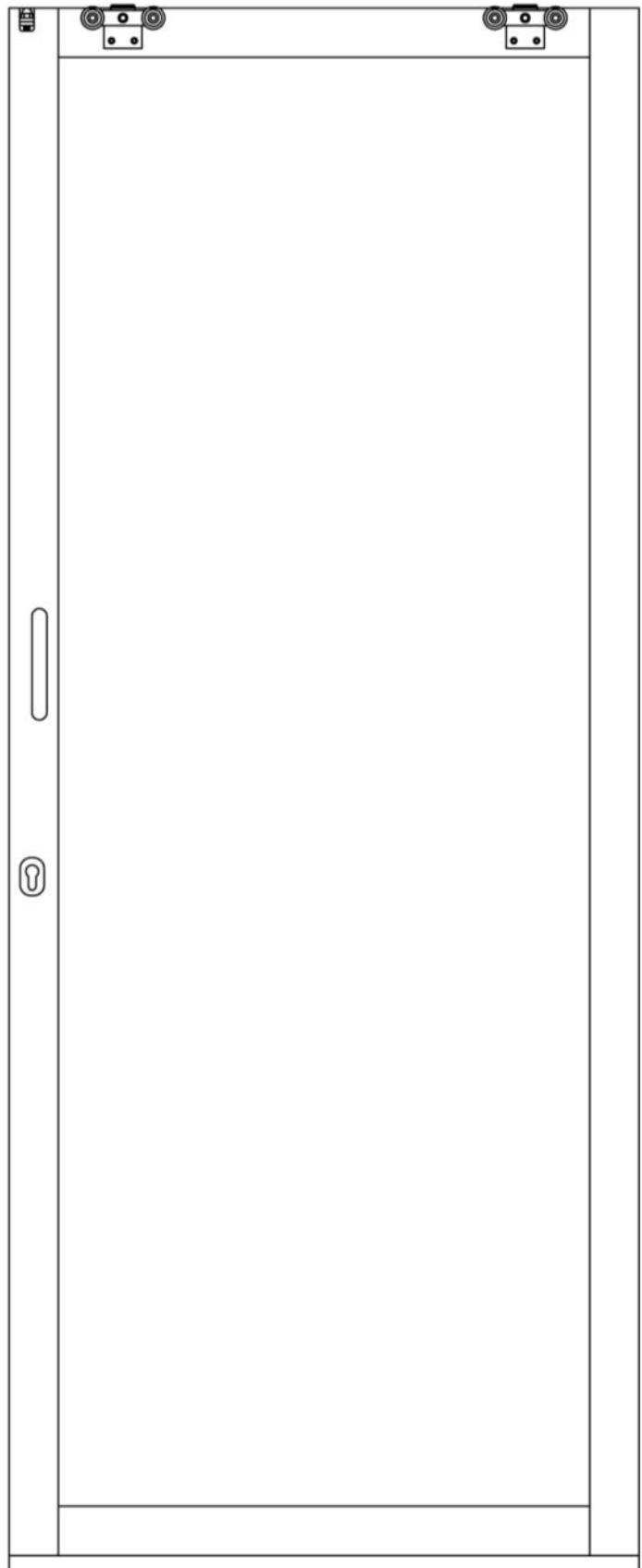

# Porte coulissante Lounge vitrée 33.2

## Serrure 1 point haut

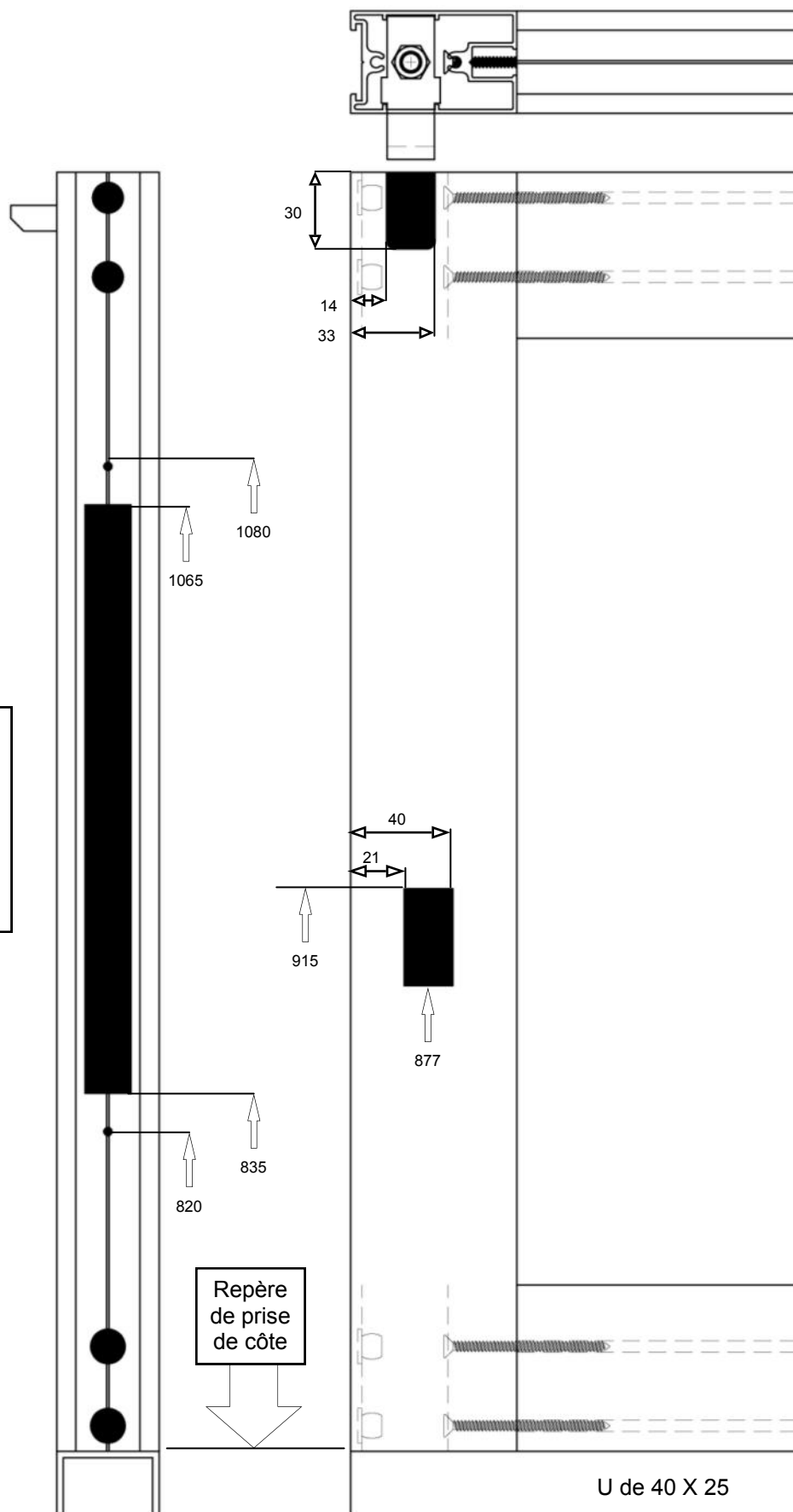

Usinage pour  
Serrure 1 point  
à tringle ronde  
SER2PTTR  
coffre de 41 mm  
Ref :2253.41.0

Repère  
de prise  
de côte

U de 40 X 25

# Porte coulissante Lounge vitrée 33.2

## Serrure 1 point haut

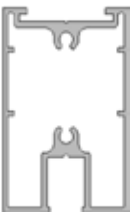
	PP65V
	U de 40 X 25
	JVP
	Serrure 1 point SER2PTTR Coffre de 41
	Cylindre Eu 35x35
	Butée d'arrêt
	Guide bas
	Poignée coquille inox
	Entrée de cylindre inox
	Joint brosse autocollant
	Anti- débondage

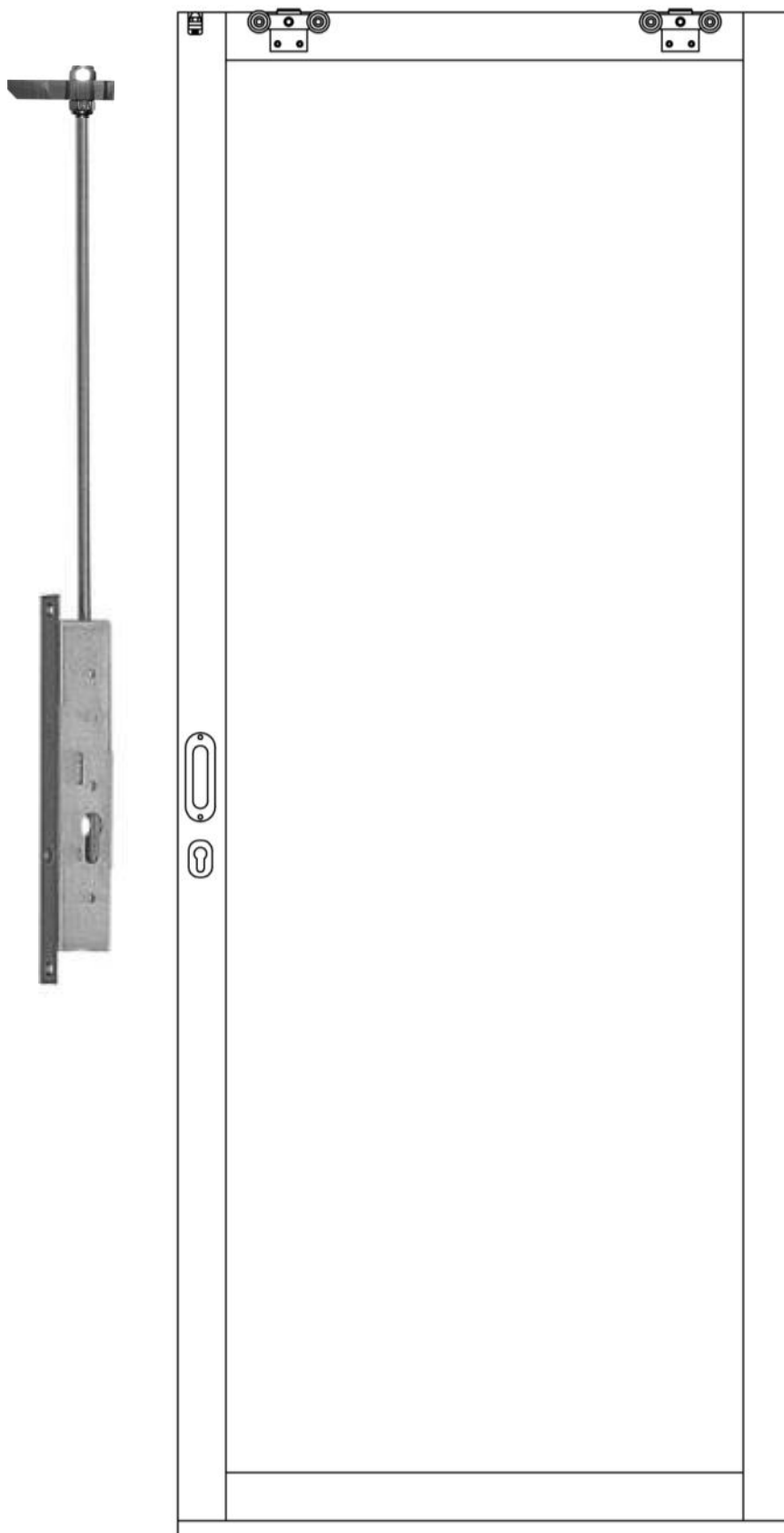

# Porte coulissante Lounge vitrée 33.2

## Serrure 1 point haut

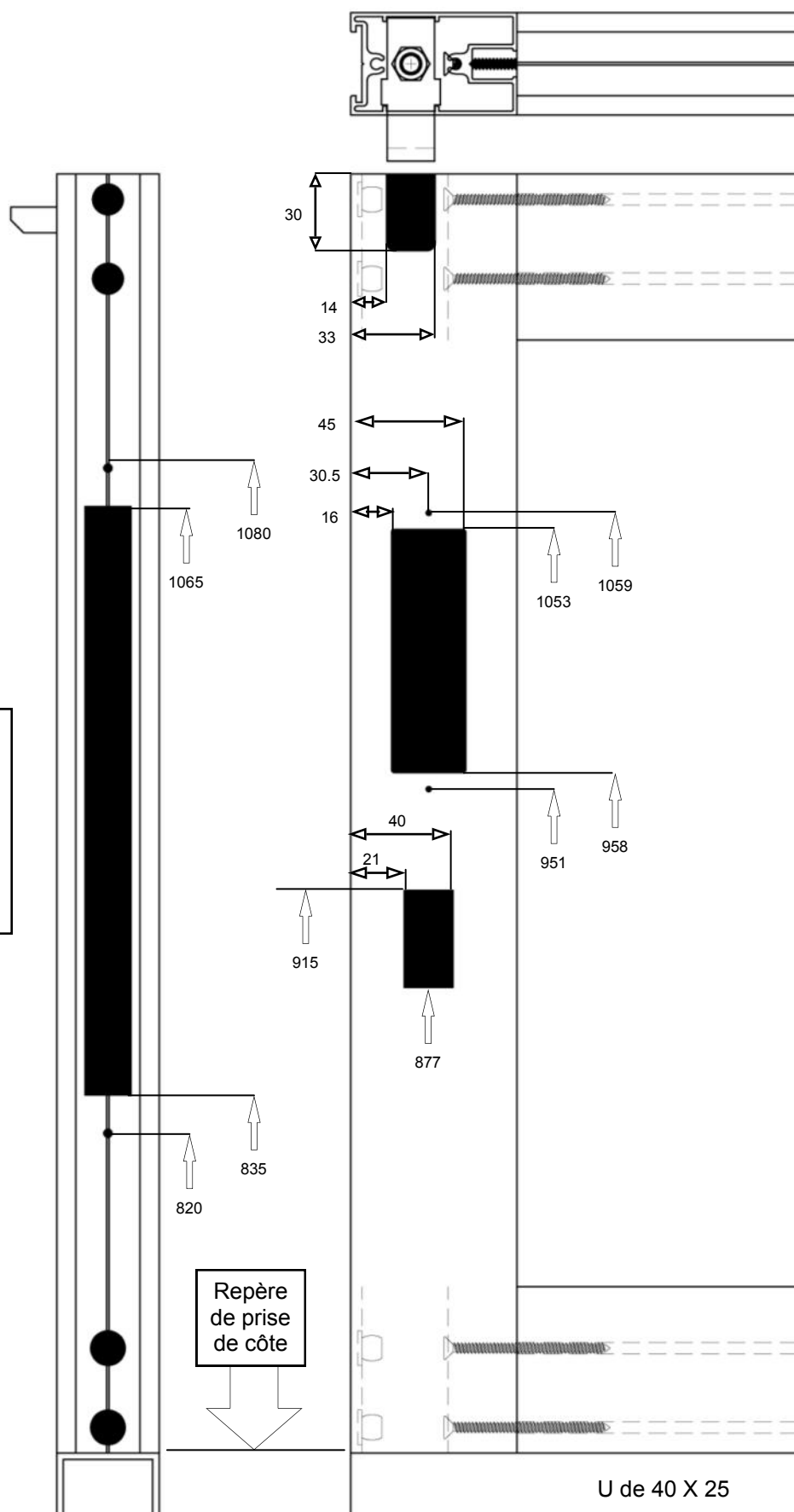

Usinage pour  
Serrure 1 point  
à tringle ronde  
SER2PTTR  
coffre de 41 mm  
Ref :2253.41.0

# Porte coulissante Lounge vitrée 33.2 sur cloison Série 65 Serrure 1 point haut

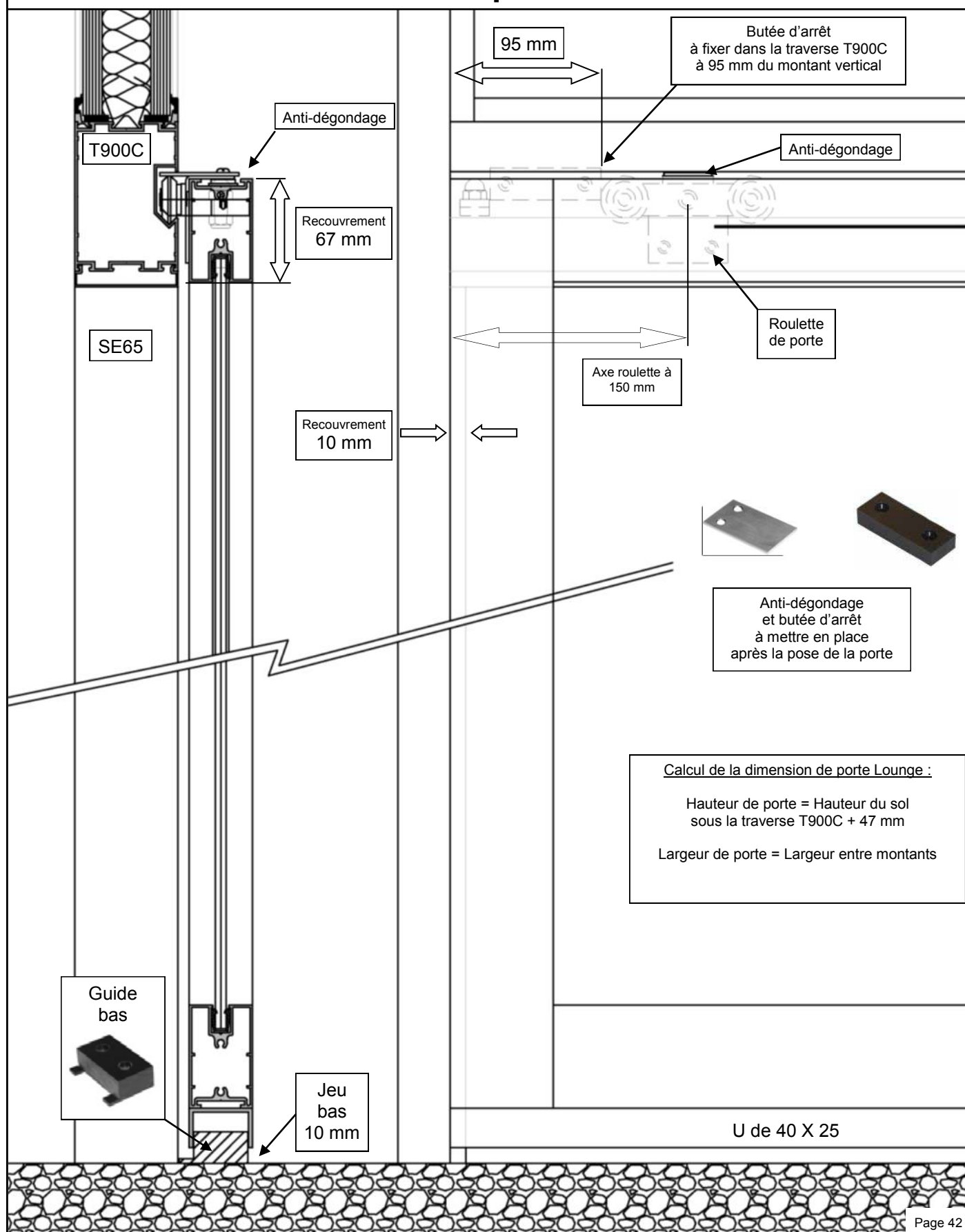

# Porte coulissante Lounge vitrée 33.2 sur cloison Mistral 85 Serrure 1 point haut

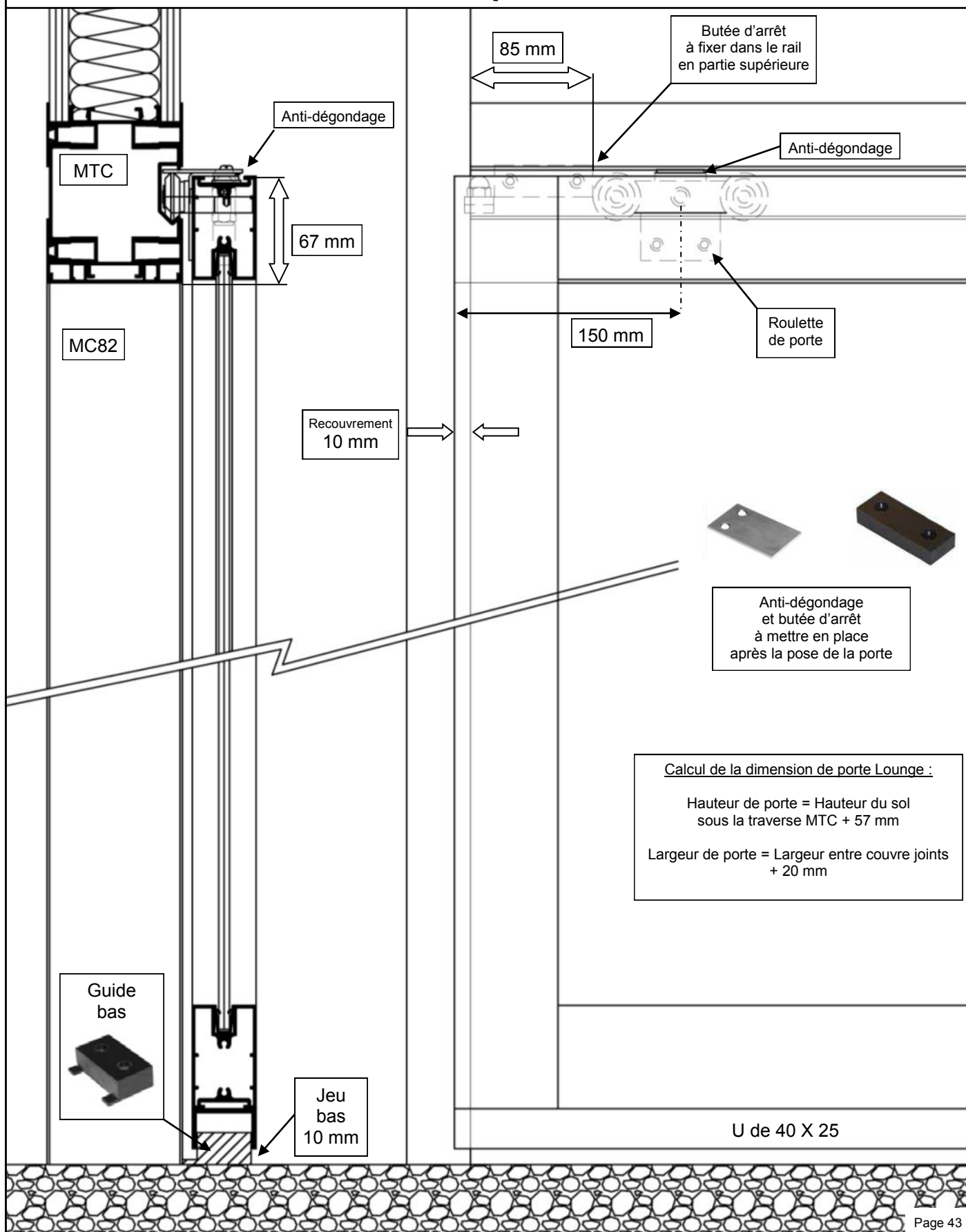

# Côtes d'implantation des paumelles sur battant hauteur 2040 mm

## KIT1PUB (porte bois) KIT1PUA (porte alu.)

Côtes du bas de la porte au dessous des paumelles

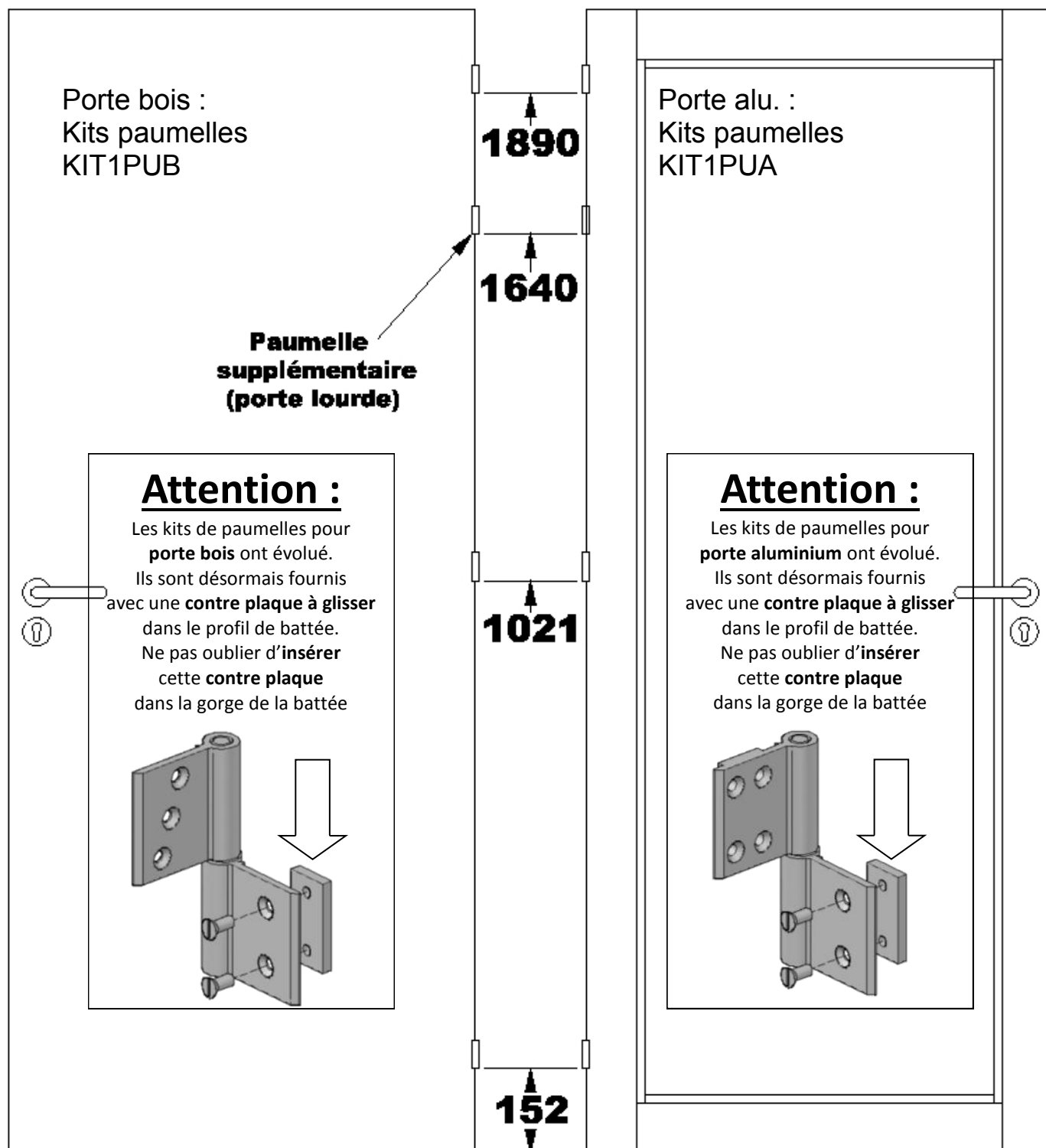

Longueurs de débit du JB17 pour des portes alu standard OZ alu Ht 2040 :

3 paumelles : 112 mm / 819 mm / 819 mm / 162 mm

4 paumelles : 112 mm / 819 mm / 569 mm / 200 mm / 162 mm

Côté gâche : 910 mm / 995 mm    Traverse haute : largeur porte + 9 mm

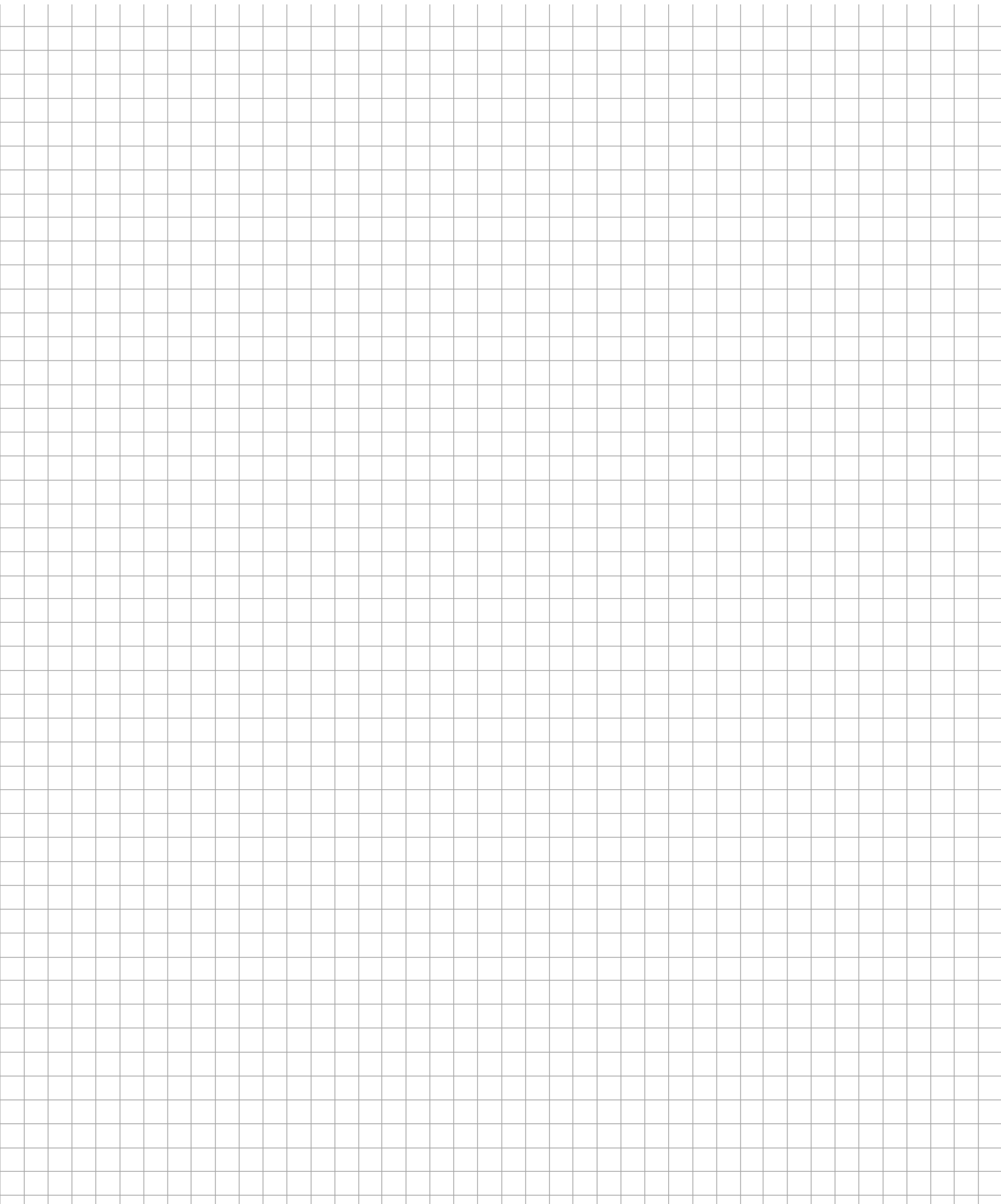

# NOTES & CROQUIS

